



**IN LINE WITH
YOUR BUSINESS**

est
Line

TECHNICAL CASES

AN ITALIAN

COMPANY
EN



WORK
by *GT Line*



EXPLORER
CASES



INDEX

GT Line

All in One	pag.10
AtomikNeo M New	pag.27
AtomikNeo Wh New	pag.30
V-Rock Turtle	pag.34
Rock Turtle	pag.37
New Mega Wheels	pag.40
Bomber170 PEL	pag.43
Atomik215	pag.44
Atomik Wh	pag.47
GT 44-19 PTS	pag.50
GT 48-25HL	pag.52
GT 52-21	pag.55
GT 53-26 PEL	pag.58
Boxer	pag.60
Boxer Wh	pag.63
Revo21	pag.66
Revo21 Wh	pag.69
R7 Top - Alc/170	pag.72
Flash	pag.74
Flash Wh 2 PEL	pag.76
Mub	pag.77

Work Line by GT

Monolith Cross LT40 New	pag.86
Monolith LT20 New	pag.88
Monolith LT35	pag.90
Top 07 R - Top 10 R	pag.92
Bag 07 R	pag.94
Tool Trolley 01 R	pag.95
Soft Trolley 01 R	pag.97
Soft Pilot R	pag.99
Bag & Case PTS R	pag.101
PSS Compact Bag R	pag.102
Top 04 R - Top 06 R - Top 08 L R	pag.103
Bag R	pag.105
Top Belt R - Top Electra R	pag.108
Top Tool Belt R - Top Drill R	pag.109
Top Nail R - Top Tape Plus R	pag.110
Top Bumbag R	pag.111
Tool Rooll	pag.112

Explorer Cases

pag.118



Since 1970 **GT Line** has been synonymous with excellence in the design and manufacturing of technical cases and custom professional containers.

Each product is born from a passion for innovation and a commitment to meeting the specific needs of every industry, ensuring uncompromising performance in any situation.

With over 55 years of experience and UNI EN ISO 9001:2015 certification, **the company manufactures** a wide range of professional cases, tool bags, waterproof and large size **containers entirely within its own facilities in Italy, Romania and Vietnam.**

Thanks to advanced robotic technologies and processes focused on energy efficiency and environmental sustainability, GT line offers **high-quality products** that combine **innovation, strength, lightness, functionality and aesthetics**, using carefully selected high performance materials.



KEY STRENGTHS



SPECIALIZATION
(more than 55 years of expertise)



PRODUCT RANGE
extensive and diversified product range

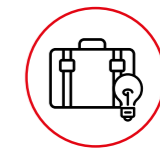

INNOVATION
continuous innovation



PRODUCTION
100% in house

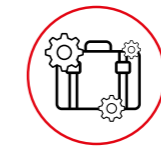

TECHNOLOGIES
wide range of advanced and innovative technologies



PASSION
drives our commitment to excellence



QUALITY
uncompromising and efficient



SPARE PARTS
availability of spare parts for all its products



CUSTOMIZATION
extensive product customization capabilities



PARTNERSHIP
co-design



OUR BRANDS



Robust and functional technical tool cases, engineered for durability and practicality, ideal for professionals across multiple industries.



Lightweight tool bags and backpacks made of durable fabrics, built for everyday use, comfort and professional style.



Professional waterproof cases engineered to ensure maximum protection for sensitive equipment and delicate instruments, even in the most demanding environments.



OUR SERVICES

The GT Line Group team provides advanced customization services for technical cases, tailoring each solution to specific tools and professional applications. Beyond ensuring superior protection and organization, the company offers the integration of personalized graphics, enhancing brand visibility and delivering a powerful visual identity on every case.

Customize

GT Line's customized interiors, with pre-cubed or tailor-cut foam inserts, are designed to protect and enhance every instrument. Using advanced technologies such as laser cutting, pressing, water jet and milling, the company delivers ideal solutions to meet specific customer needs.

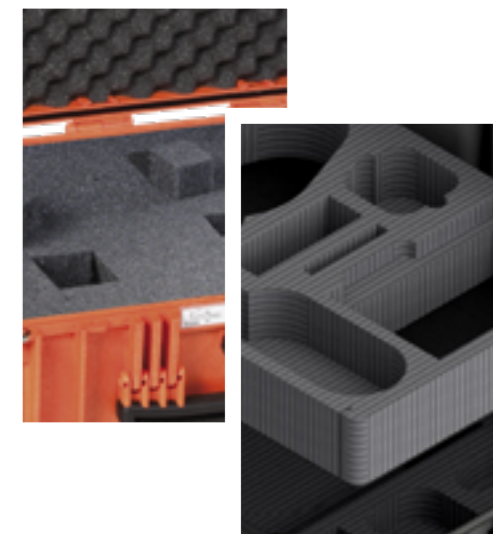

Protect and Organize

GT Line offers an extensive selection of complementary accessories, including pocket and elastic panels, dividers, locks, padded bags, backpacks and internal supports, carefully selected to suit the intended use of each case. These accessories complete the customization of our tool cases and high-performance containers, ensuring maximum protection, organization and attention to detail for every professional application.



GT Line also provides advanced aesthetic customization through UV printing, allowing clients to reproduce their brand communication directly on the external surfaces of their preferred professional cases.









brand of 
Line
group



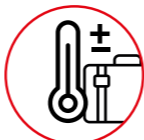
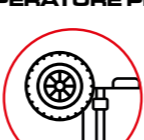

- 
CORROSION PROOF
- 
WATER-RESISTANT
- 
SHOCK PROOF
- 
HIGH & LOW TEMPERATURE PROOF
- 
WHEELS & TELESCOPIC HANDLE - TROLLEY
- 
AIRPORT HANDLING RESISTANT
- 
STACKABLE

ALL IN ONE MODULAR SYSTEM

Modular excellence designed for the most demanding professionals.

All in One Modular System is an innovative, fully modular, and customizable tool transport system designed to meet the needs of the most demanding industries, including **aerospace maintenance, industrial manufacturing and precision engineering.**

Combining robustness, flexibility and intelligent internal organization, this system ensures flawless management of professional tools, enhancing efficiency, safety and operational speed. All in One Modular System is the ideal solution for professionals who demand maximum performance, order and reliability in the transport of their tools.

All in One Modular System

This modular transport system, available in various sizes and configurations, consists of a series of stackable container models that can be customized with a wide range of accessories.

MODEL RANGE

<p>A11 Drawer</p> <p>Tool trolleys engineered to hold AIDRAW drawers in multiple configurations.</p> 	<p>A11X Organizer</p> <p>Tool trolleys engineered to hold AIBOX organizers in multiple configurations.</p> 	<p>A11MOD</p> <p>Tool cases available in multiple sizes, designed to be perfectly stackable on A11 and A11X trolleys.</p> 
--	--	---

STACKABLE

<p>A11MOD16</p> <p>A11MOD31 A11MOD31X</p> <p>A11/A11X</p> 		<p>ALL IN ONE MODULAR SYSTEM</p> 
--	---	---

CUSTOMIZABLE

 <p>ACCESSORIES</p>		 <p>BOX WL</p> <p>AIDRAW</p> <p>AIBOX</p> <p>AIPANEL</p>
---	---	---

All in One Modular System: solutions

1. ALL IN ONE – Injection-moulded sturdy tool trolley, made of extremely impact-resistant materials. Ideal for intensive use in demanding environments, it is available in multiple configurations as further detailed below. Featuring a strong telescopic handle, durable wheels and a front lid that opens 180°, this trolley combines efficiency, strength and functionality for professional applications.



2. A11MOD – Modular interlocking tool cases compatible with the A11 trolley to create a spacious and configurable wheeled transport system. Injection-moulded for strength and durability, they are available in various sizes, either empty or equipped with a removable tray and customizable internal panels:

- PEL (with elastic loops)
- PTS (with FLEXI POUCHES™ pockets)
- PSS (with the PSS™ system)

3. AIDRAW – Durable polypropylene drawers available in three heights (30, 60 and 95 mm), ideal for storing small parts and accessories.

- Configurable options:
- Empty (.E)
 - With bi-color pre-cubed foam (.F)
 - With removable trays and dividers (.B1)

10 AVAILABLE CONFIGURATIONS

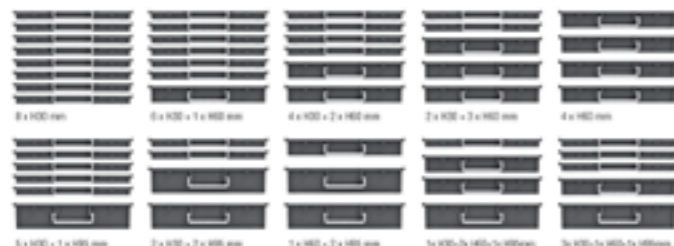

ITEM DRAWER	INT. CONFIG.	INT. DIM (mm)
AIDRAW3.E	Empty	467 X 255 X H30
AIDRAW3.F	With Foam	467 X 255 X H30
AIDRAW6.E	Empty	467 X 255 X H60
AIDRAW6.F	With Foam	467 X 255 X H60
AIDRAW6.B1	BIN BOXES	467 X 255 X H60
AIDRAW9.E	Empty	467 X 255 X H95
AIDRAW9.F	With Foam	467 X 255 X H95
AIDRAW9.B1	BIN BOXES	467 X 255 X H95

8 AVAILABLE CONFIGURATIONS

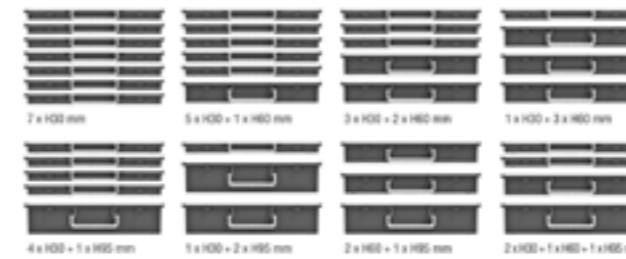

4. AIBOX – Organizers made with AIDRAW drawers featuring a removable transparent lid. Practical polypropylene organizers available in three heights (30, 60 and 95 mm).

- Configurable options:
- Empty (.E)
 - With bi-color pre-cubed foam (.F)
 - With removable trays and dividers (.B1)

ITEM Organizer	INT. CONFIG.	INT. DIM (mm)
AIBOX3.E	Empty	467 X 255 X H30
AIBOX3.F	With Foam	467 X 255 X H30
AIBOX6.E	Empty	467 X 255 X H60
AIBOX6.F	With Foam	467 X 255 X H60
AIBOX6.B1	BIN BOXES	467 X 255 X H60
AIBOX9.E	Empty	467 X 255 X H95
AIBOX9.F	With Foam	467 X 255 X H95
AIBOX9.B1	BIN BOXES	467 X 255 X H95

5. SMALL BOXES WL – Small parts boxes included in selected A11 models or available separately. They come in two widths (163 mm and 245 mm) and offer various internal configurations: empty or with 6, 10, or 11 compartments.



6. AIPANEL – Various types of tool panels designed to optimize internal organization:

- AIPANEL PSS: Drawer panels (low, medium, high)
- AIPANEL PEL / PTS / PFR: Lid panels with elastic loops, pockets, or adjustable bands
- AIPANEL IPAD: Lid panel with dedicated tablet pocket and PSS system
- AIPANEL PLEXI: Transparent hinged cover designed to secure foam inserts or technical documentation.

7. AIWHEELS – Optional wheel kit with four swivel castors, including two with brake, for even easier and smoother mobility.



8. A11LID – Lid designed for A11 models, developed to upgrade previous versions and make them compatible and stackable with the new AIMOD modules.



A11

Polypropylene tool trolleys designed to accommodate organizers or removable drawers, available either empty or equipped.

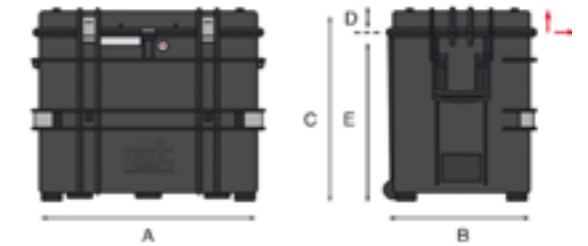

A11					
DIMENSIONS (mm)	A	B	C	D	E
INTERNAL	516	296	402	50	352
EXTERNAL	585	389	466		
Dimensional Tolerance	+/-1.5% from nominal dimensions				



REMOVABLE TRAY



TECHNICAL FEATURES	
Wheels	Self-lubricating wheels.
Handles	Telescopic handle. 2 Foldable side handles.
Tray	Removable top tray.
Name Tag	Name tag holder.
Locks	1 key lock. Padlockable at multiple points.
Lids	Removable top lid equipped with safety lock. Removable front lid.
Stackable	Yes. The patented LOCK/UNLOCK system enables quick, one-handed unlocking of every box.
IntelliRespond	Yes



THIS PRODUCT CAN BE USED WITH OUR APP
INTELLIRESPOND

www.intellirespond.com



**A11 - without drawers**

- EAN: 8024482178745
- Designed to accommodate drawers
- 2 Component boxes for small parts h 30 mm with 6 compartments (mod. WL01)
- 2 Component boxes for small parts h 30 mm with 13 compartments (mod. WL02)
- 1 Component box for small parts h 30 mm with 10 compartments (mod. WL04)
- Weight: kg 10.85
- Load capacity: kg 40.00

**A11.KT02 - with empty drawers**

- EAN: 8024482178936
- 1 Empty drawer h 30 mm
- 2 Empty drawers h 60 mm
- 1 Empty drawer h 95 mm with:
 - 2 Component boxes for small parts h 30 mm with 6 compartments (mod. WL01)
 - 2 Component boxes for small parts h 30 mm with 13 compartments (mod. WL02)
 - 1 Component box for small parts h 30 mm with 10 compartments (mod. WL04)
- Weight: kg 14.17
- Load capacity: kg 40.00

**A11.KT01 - with equipped drawers**

- EAN: 8024482178752
- 1 Drawer, h 30 mm, fitted with bi-colour pre-cubed foam, height 30 mm
- 1 Drawer, h 60 mm, equipped with 23 removable small-parts bins (4 bins 12.5 × 21 cm with dividers + 3 bins 4×8 cm)
- 1 Drawer, h 60 mm, fitted with bi-colour pre-cubed foam, height 30 mm
- 1 Drawer, h 95 mm, with:
 - 2 Component boxes for small parts h 30 mm with 6 compartments (mod. WL01)
 - 2 Component boxes for small parts h 30 mm with 13 compartments (mod. WL02)
 - 1 Component box for small parts h 30 mm with 10 compartments (mod. WL04)
- Weight: kg 14.67
- Load capacity: kg 40.00

**A11X.B - without organizer**

- EAN: 8024482183596
- Designed to accommodate organizer
- 2 Component boxes for small parts h 30 mm with 6 compartments (mod. WL01)
- 2 Component boxes for small parts h 30 mm with 13 compartments (mod. WL02)
- 1 Component box for small parts h 30 mm with 10 compartments (mod. WL04)
- Weight: kg 10.85
- Load capacity: kg 40.00

**A11X.B.2LR - with empty organizer**

- EAN: 8024482183602
- 2 Empty organizer h 60 mm
- 1 Empty organizer h 95 mm
- 2 Component boxes for small parts h 30 mm with 6 compartments (mod. WL01)
- 2 Component boxes for small parts h 30 mm with 13 compartments (mod. WL02)
- 1 Component box for small parts h 30 mm with 10 compartments (mod. WL04)
- Weight: kg 14.05
- Load capacity: kg 40.00

**A11X.B.LMT - with equipped organizer**

- EAN: 8024482183619
- 1 Empty organizer h 60 mm with:
 - 2 Component boxes for small parts h 30 mm with 6 compartments (mod. WL01)
 - 2 Component boxes for small parts h 30 mm with 13 compartments (mod. WL02)
 - 1 Component box for small parts h 30 mm with 10 compartments (mod. WL04)
- 1 Organizer h 60 mm fitted with bi-colour pre-cubed foam, height 30 mm
- 1 Organizer h 95 mm with 23 removable component boxes for small parts:
 - 4 Bin boxes 12.5x21 cm with dividers
 - 3 Bin boxes 4x8 cm
- Weight: kg 14.05
- Load capacity: kg 40.00

AI1 MOD



The AI1MOD tool case is a compact and robust module designed to expand the capacity of GT Line's ALL IN ONE system. Perfect as a stand-alone tool case or as an integrated professional storage module.

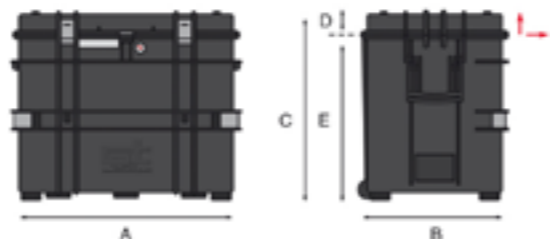

AI1MOD16					
DIMENSIONS (mm)	A	B	C	D	E
INTERNAL	516	296	160	50	110
EXTERNAL	585	368	198		
Dimensional Tolerance	+/-1.5% from nominal dimensions				
AI1MOD31					
INTERNAL	516	296	310	60	250
EXTERNAL	585	368	348		
Dimensional Tolerance	+/-1.5% from nominal dimensions				
AI1MOD31X					
INTERNAL	483	296	310	60	250
EXTERNAL	585	368	348		
Dimensional Tolerance	+/-1.5% from nominal dimensions				

TECHNICAL FEATURES	
Handles	Ergonomic handles with rubber coating.
Locks	Reinforced metal closures with padlock holes.
Name Tag	1 Name Tag.
Stackable	Yes. The patented LOCK/UNLOCK system enables quick, one-handed unlocking of every box.
IntelliRespond	Yes
Material	Polypropylene.
Lid	Removable cover with patented stacking system for attaching AI1MOD modules.



AI1 MOD



AI1MOD16

- EAN: 8024482191461
- Completely empty case
- The smart way to expand your AI1 system
- Can also be used as a stand-alone unit
- A lightweight but strong design
- Weight: kg 3.21
- Load capacity: kg 25.00



AI1MOD16 PEL

- EAN: 8024482191478
- Tool case equipped with elastic-loop panels for tool organization
- The smart way to expand your AI1 system
- Can also be used as a stand-alone unit
- 2 Tool panels with elastic loops
- Weight: kg 4.11
- Load capacity: kg 25.00



AI1MOD16 PTS

- EAN: 8024482191485
- Tool case equipped with practical pockets for organized storage
- The smart way to expand your AI1 system
- Can also be used as a stand-alone unit
- 2 Tool panels with FLEXI POUCHES™ pockets
- Weight: kg 4.11
- Load capacity: kg 25.00



AI1 MOD 16 PSS

- EAN: 8024482191492
- Tool case equipped with practical pockets for organized storage
- The smart way to expand your AI1 system
- Can also be used as a stand-alone unit
- 2 Tool panels with PSS™ pocket system
- Weight: kg 4.51
- Load capacity: kg 25.00



AI1 MOD 31

- EAN: 8024482191508
- Empty case with removable tray
- The smart way to expand your AI1 system
- Can also be used as a stand-alone unit
- Weight: kg 4.79
- Load capacity: kg 30.00



AI1 MOD 31X

- EAN: 8024482191690
- Empty case designed to hold AIBOX modules
- The smart way to expand your AI1 system
- Can also be used as a stand-alone unit
- Weight: kg 5.31
- Load capacity: kg 30.00

**EQUIPPED WITH
AIBOX
ACCESSORIES**



AI1 LID

- EAN: 8024482191515
- AI1 lid designed to upgrade earlier models (up to 2024), ensuring full compatibility and stackability with the new AIMOD modules
- Weight: kg 1.51



NEW!
Atomik NEO/Atomik WH NEO



CORROSION PROOF



SHOCK PROOF

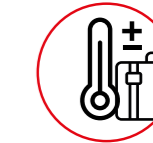

**HIGH & LOW
TEMPERATURE PROOF**

ATOMIK NEO M

New energy for professional protection

Atomik Neo M reinterprets a GT Line icon with a modern design and advanced functional solutions. The deeper base, new bumpers and the ergonomic two-tone handle enhance **comfort, capacity** and **durability**.

The key lock and **RFID**-ready configuration complete a case engineered for today's professional security needs.

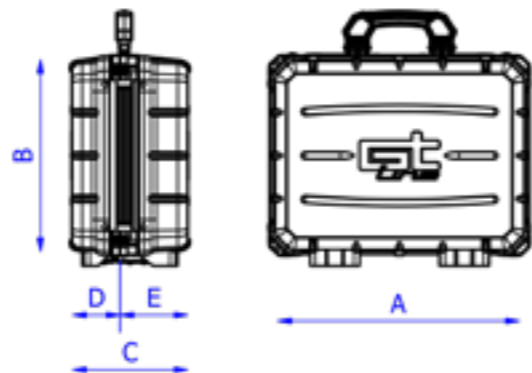
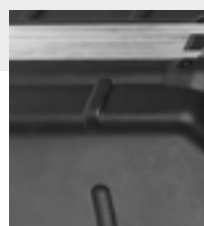

ATOMIKNEO M PEL/PTS/PSS					
DIMENSIONS (mm)	A	B	C	D	E
INTERNAL	468	351	208	78	130
EXTERNAL	485	419	222		
Dimensional Tolerance	+/-1.5% from nominal dimensions				



TECHNICAL FEATURES	
Handles	Ergonomic two-tone handle.
Locks	2 Key locks.
Base	High-capacity base.
Bumpers	New bumpers.
RFID	RFID-ready.
Name Tag	Integrated name tag holder.
Hinges	Integrated lid hinges with built-in lid stay support.
Airtag Holder	Airtag holder (Apple).
Assembly	All components assembled with mechanical fasteners (easy to dispose of or replace). Main wear parts assembled with screws for easy replacement.

ACCESSORIES	WL01	WL02	WL03	WL04	WL05	FOAM ATOMIK	LOCK ATOMIK	PAN ATOMIK	KEYLOCKATOMIK
	Atomik NEO M PEL	■	■	■	■	■	■	■	■
Atomik NEO M PTS	■	■	■	■	■	■	■	■	■
Atomik NEO M PSS	■	■	■	■	■	■	■	■	■

ATOMIKNEO M PEL



- EAN: 8024482193670
- 1 Tool panel with elastic straps on two sides
- 1 Tool panel with elastic straps on one side
- 2 Key locks
- 3 Component boxes
- Document pocket
- Weight kg 6.00
- Load capacity kg 20.00

ATOMIKNEO M PTS



- EAN: 8024482193694
- 1 Tool panel with FLEXI POUCHES™ pockets on both sides
- 1 Tool panel with FLEXI POUCHES™ pockets on one side
- 2 Key locks
- 3 Component boxes
- Document pocket
- Weight kg 6.10
- Load capacity kg 20.00

ATOMIKNEO M PSS



- EAN: 8024482193687
- 1 Lid tool pallet with with PSS™ system on one side
- 1 Middle tool pallet with PSS™ system on both sides
- 1 Bottom pallet with PSS™ system on one side
- 2 Key locks
- 3 Component boxes
- Document pocket
- Weight kg 6.60
- Load capacity kg 20.00





ATOMIK NEO WH

New energy for professional mobility

Atomik Neo WH refreshes the GT Line professional trolley with an innovative design and smart solutions engineered for those who are always on the move. The deeper base, new bumpers, ergonomic two-tone handle and telescopic pull handle enhance **comfort, protection** and **practicality**, while the **oversized 100 mm wheels** with bearings ensure superior smooth rolling performance.

The key lock on the M version, combination lock on the L version and **RFID**-ready configuration complete a trolley designed for professional security and efficiency.

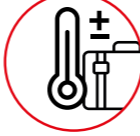
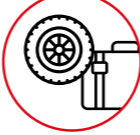
-  CORROSION PROOF
-  SHOCK PROOF
-  HIGH & LOW TEMPERATURE PROOF
-  WHEELS & TELESCOPIC HANDLE - TROLLEY



Only in Atomik WH Neo L

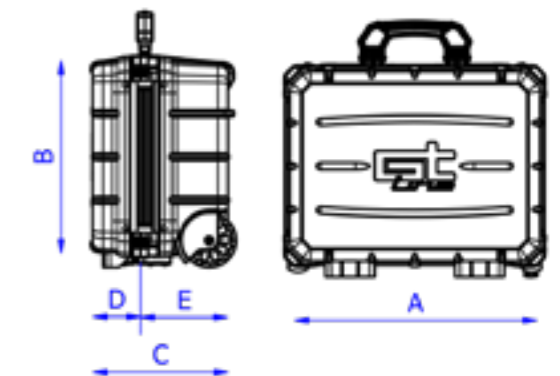

ATOMIKNEOWH M PEL/PTS/PSS					
DIMENSIONS (mm)	A	B	C	D	E
INTERNAL	468	351	245	78	167
EXTERNAL	485	419	265		
Dimensional Tolerance	+/-1.5% from nominal dimensions				
ATOMIKNEOWH L PEL/PTS/PSS					
INTERNAL	468	351	267	100	167
EXTERNAL	485	419	287		
Dimensional Tolerance	+/-1.5% from nominal dimensions				

TECHNICAL FEATURES	
Handles	Ergonomic two-tone handle. Telescopic pull handle.
Locks	2 Locks with keys. 2 Combination locks (only in the L version).
Base	Extra high-capacity base.
Bumpers	New bumpers.
RFID	RFID-ready.
Name Tag	Integrated name tag holder.
Wheels	Extra-large Ø 100 mm wheels with bearings.
Hinges	Integrated lid hinges with built-in lid stay support.
Airtag Holder	Airtag holder (Apple).
Assembly	Mechanical fasteners for easy disposal or replacement. Main wear parts assembled with screws.



ACCESSORIES	WL01	WL02	WL03	WL04	WL05	FOAM ATOMIK	LOCK ATOMIK	PAN ATOMIK	KEYLOCKATOMIK
	ATOMIKNEOWH PEL	■	■	■	■	■	■	■	■
ATOMIKNEOWH PTS	■	■	■	■	■	■	■	■	■
ATOMIKNEOWH PSS	■	■	■	■	■	■	■	■	■

✓ Availability of all spare parts.

**ATOMIKNEOWH M PEL**

- EAN: 8024482193700
- 1 Tool panel with elastic straps on two sides
- 1 Tool panel with elastic straps on one side
- 2 Key locks
- 2 Component boxes
- Document pocket
- Weight kg 7.30
- Load capacity kg 25.00

**ATOMIKNEOWH L PEL**

- EAN: 8024482193731
- 1 Tool panel with elastic straps on two sides
- 1 Tool panel with elastic straps on one side
- 2 Combination locks
- 3 Component boxes
- Document pocket
- Weight kg 7.70
- Load capacity kg 25.00

**ATOMIKNEOWH M PTS**

- EAN: 8024482193724
- 1 Tool panel with FLEXI POUCHES™ pockets on both sides
- 1 Tool panel with FLEXI POUCHES™ pockets on one side
- 2 Key locks
- 2 Component boxes
- Document pocket
- Weight kg 7.40
- Load capacity kg 25.00

**ATOMIKNEOWH L PTS**

- EAN: 8024482193755
- 1 Tool panel with FLEXI POUCHES™ pockets on both sides
- 1 Tool panel with FLEXI POUCHES™ pockets on one side
- 2 Combination locks
- 3 Component boxes
- Document pocket
- Weight kg 7.80
- Load capacity kg 25.00

**ATOMIKNEOWH M PSS**

- EAN: 8024482193717
- 1 Lid tool pallet with with PSS™ system on one side
- 1 Middle tool pallet with PSS™ system on both sides
- 1 Bottom pallet with PSS™ system on one side
- 2 Key locks
- 2 Component boxes
- Document pocket
- Weight kg 7.90
- Load capacity kg 25.00

**ATOMIKNEOWH L PSS**

- EAN: 8024482193748
- 1 Lid tool pallet with with PSS™ system on one side
- 1 Middle tool pallet with PSS™ system on both sides
- 1 Bottom pallet with PSS™ system on one side
- 2 Combination locks
- 3 Component boxes
- Document pocket
- Weight kg 8.40
- Load capacity kg 25.00



V-ROCK TURTLE

Durable and secure, suitable for air travel.

V-Rock Turtle case is the perfect solution for professionals seeking a product that combines **exceptional strength, reliable protection** and **ease and comfort of transport**.

This case is made of high-strength polyethylene, featuring an aluminium frame and reinforced corners. It is equipped with Ø 120 mm wheels with sealed ball bearings and a telescopic handle, ensuring smooth mobility and long-lasting performance.



AIRPORT HANDLING RESISTANT

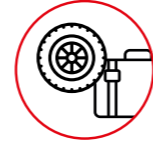

WHEELS & TELESCOPIC HANDLE - TROLLEY



CORROSION PROOF



SHOCK PROOF

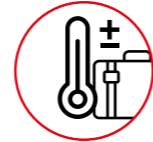

HIGH & LOW TEMPERATURE PROOF



STACKABLE



V-ROCK TURTLE PEL/PTS/PSS					
DIMENSIONS (mm)	A	B	C	D	E
INTERNAL	470	385	330	137	193
EXTERNAL	539	446	385		
Dimensional Tolerance	+/-1.5% from nominal dimensions				



TECHNICAL FEATURES	
Wheels	120 mm Ø Wheels with sealed ball bearings.
Handles	Telescopic handle. 2 Ergonomic rubber-coated handles.
Arms	2 Gas pressurised lid supports.
Document Holder	Document pocket.
Locks	2 TSA approved key locks.
Base	Spacious base for tools.
Hinges	Steel hinge riveted in several points.
Box	3 Component boxes.
Nameplate	Name tag.
Stackable	Yes
IntelliRespond	Yes

ACCESSORIES	WL01	WL02	WL03	WL04	WL05
	V-Rock Turtle PEL	■	■	■	■
V-Rock Turtle PTS	■	■	■	■	■
V-Rock Turtle PSS	■	■	■	■	■

✓ Availability of all spare parts.

V-ROCK TURTLE





V-ROCK TURTLE PEL

- EAN: 8024482185231
- 1 Tool panel with elastic straps on two sides
- 1 Tool panel with elastic straps on one side
- 2 TSA LOCK™ approved key locks
- 3 Component boxes
- Document pocket
- Weight kg 8.80
- Load capacity kg 40.00



V-ROCK TURTLE PTS

- EAN: 8024482185255
- 1 Tool panel with FLEXI POUCHES™ pockets on both sides
- 1 Tool panel with FLEXI POUCHES™ pockets on one side
- 2 TSA LOCK™ approved key locks
- 3 Component boxes
- Document pocket
- Weight kg 8.90
- Load capacity kg 40.00



V-ROCK TURTLE PSS

- EAN: 8024482185248
- 1 Lid tool pallet with with PSS™ system on one side
- 1 Middle tool pallet with PSS™ system on both sides
- 1 Bottom pallet with PSS™ system on one side
- 2 TSA LOCK™ approved key locks
- 3 Component boxes
- Document pocket
- Weight kg 9.20
- Load capacity kg 40.00



AIRPORT HANDLING
RESISTANT

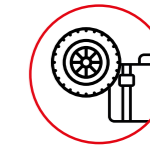

WHEELS & TELESCOPIC
HANDLE - TROLLEY



CORROSION PROOF



SHOCK PROOF

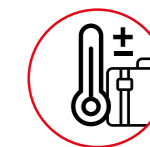

HIGH & LOW
TEMPERATURE PROOF

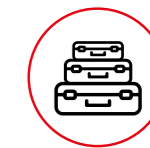

STACKABLE

ROCK TURTLE

Strong and perfect for air transport

Rock Turtle case is the ideal companion for professionals seeking **strength, security** and practicality in a single product. Made of high-strength polyethylene with aluminium reinforcements and protected corners, it ensures **excellent protection for your tools** even in demanding environments or during the most challenging transport conditions.

Thanks to its ball-bearing wheels and integrated telescopic handle, Rock Turtle moves smoothly and effortlessly, even on uneven surfaces.

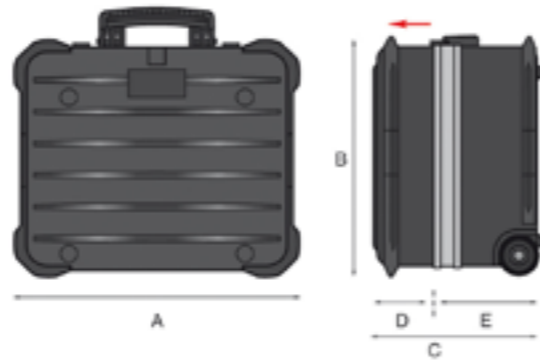

ROCK TURTLE PEL/PTS/PSS					
DIMENSIONS (mm)	A	B	C	D	E
INTERNAL	470	390	300	106	194
EXTERNAL	517	453	349		
Dimensional Tolerance	+/-1.5% from nominal dimensions				



Upgrade to gas-spring supports being implemented/coming soon



TECHNICAL FEATURES	
Wheels	2 Wheels with ball bearings.
Handles	1 Ergonomic handle with rubber coating. 1 Telescopic handle.
Arms	2 Gas lid support arms.
Document Holder	1 Document pocket.
Locks	2 TSA approved key locks.
Base	Spacious base for tools.
Hinges	Steel hinge riveted in several points.
Box	2 Component boxes.
Nameplate	Name tag.
Stackable	Yes
IntelliRespond	Yes



ACCESSORIES	WL01	WL02	WL03	WL04	WL05
	Rock Turtle PEL	■	■	■	■
Rock Turtle PTS	■	■	■	■	■
Rock Turtle PSS	■	■	■	■	■

ROCK TURTLE PEL



- EAN: 8024482178691
- 1 Tool panel with elastic straps on two sides
- 1 Tool panel with elastic straps on one side
- 2 TSA LOCK™ approved key locks
- 2 Component boxes
- Document pocket
- Weight kg 8.52
- Load capacity kg 40.00



ROCK TURTLE PTS



- EAN: 8024482178714
- 1 Tool panel with FLEXI POUCHES™ pockets on both sides
- 1 Tool panel with FLEXI POUCHES™ pockets on one side
- 2 TSA LOCK™ approved key locks
- 2 Component boxes
- Document pocket
- Weight kg 8.62
- Load capacity kg 40.00



ROCK TURTLE PSS



- EAN: 8024482178707
- 1 Lid tool pallet with with PSS™ system on one side
- 1 Middle tool pallet with PSS™ system on both sides
- 1 Bottom pallet with PSS™ system on one side
- 2 TSA LOCK™ approved key locks
- 2 Component boxes
- Document pocket
- Weight kg 8.92
- Load capacity kg 40.00





NEW MEGA WHEELS

Work organization and safe transport

New Mega Wheels professional trolley is the ideal solution for professionals who need safe and well-organized transport of their tools.

Thanks to its **robust double-wall construction and advanced technologies**, this tool case is designed to withstand extreme conditions while ensuring **easy and secure access** to its contents.



AIRPORT HANDLING RESISTANT

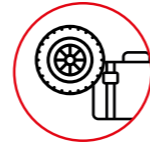

WHEELS & TELESCOPIC HANDLE - TROLLEY



CORROSION PROOF



SHOCK PROOF

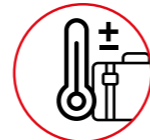

HIGH & LOW TEMPERATURE PROOF



STACKABLE



NM WHEELS

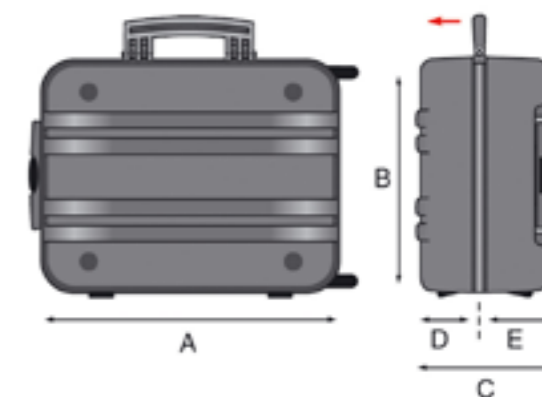

NM WHEELS PEL/PTS					
DIMENSIONS (mm)	A	B	C	D	E
INTERNAL	473	369	170	68	102
EXTERNAL	564	455	249		
Dimensional Tolerance	+/-1.5% from nominal dimensions				

TECHNICAL FEATURES	
Wheels	Big wheels with ball bearings.
Handles	Ergonomic rubber-coated handle. Telescopic handle.
Shells	Polypropylene shells featuring integrated feet.
Arms	2 Metal lid support arms.
Document Holder	Document pocket.
Locks	2 TSA approved locks with key.
Base	Base with removable and adjustable dividers.
Hinges	Steel hinge riveted in several points.
Box	2 Component boxes.
Nameplate	Name tag.
Stackable	Yes
IntelliRespond	Yes



ACCESSORIES	WL01	WL02	WL03	WL04	WL05
	NM WHEELS PEL	■	■	■	■
NM WHEELS PTS	■	■	■	■	■

✓ Availability of all spare parts.

NM WHEELS



NM WHEELS PEL

- EAN: 8024482009117
- 1 Tool panel with elastic bands on two sides
- 1 Tool panel with elastic bands on one side
- 2 Component boxes
- Document pocket
- Weight kg 7.73
- Load capacity kg 35.00



NM WHEELS PTS

- EAN: 8024482009124
- 2 Tool panels with FLEXI POUCHES™ pockets
- 2 Component boxes
- Document pocket
- Weight kg 8.13
- Load capacity kg 35.00



AIRPORT HANDLING RESISTANT



SHOCK PROOF

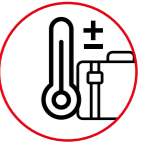

HIGH & LOW TEMPERATURE PROOF



CORROSION PROOF

BOMBER170 PEL

Extremely durable and ready for any challenge

Bomber170 is an **ultra-resistant professional case**, ideal for technicians and maintenance specialists seeking a **secure, well-organized and all-purpose tool case**.

It features a double-wall construction with **shockproof polyethylene shells**, ensuring maximum durability and protection in demanding conditions.

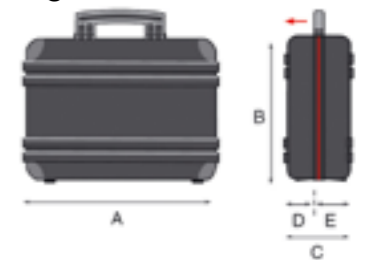

TECHNICAL FEATURES	
EAN	8024482004198
Handles	Ergonomic handle with rubber coating.
Arms	2 Metal lid support stays.
Panels	1 Tool panel with elastic straps on two sides. 1 Tool panel with elastic straps on one side.
Document Holder	Document compartment.
Locks	2 TSA approved key locks.
Hinges	1 Steel hinge riveted in various points.
Box	2 Component boxes.
Nameplate	Name tag.
Shells	Polyethylene shells featuring integrated feet.
IntelliRespond	Yes



BOMBER170 PEL					
DIMENSIONS (mm)	A	B	C	D	E
INTERNAL	429	326	174	74	100
EXTERNAL	477	408	211		
WEIGHT (kg)	5.37				
LOAD CAPACITY (kg)	30.00				
Dimensional Tolerance	+/-1.5% from nominal dimensions				
ACCESSORIES					
	WL01	WL02	WL03	WL04	WL05
BOMBER170 PEL	■	■	■	■	■



ATOMIK215

Lightweight and secure

Atomik case is the perfect solution for professionals who require **safety, strength and organization**. Made of **thick, injection-moulded polypropylene**, it provides reliable protection against **impacts, corrosive substances and extreme temperatures**.

- 
CORROSION PROOF
- 
SHOCK PROOF
- 
HIGH & LOW TEMPERATURE PROOF



TECHNICAL FEATURES	
Handles	Ergonomic handle with rubber coating.
Arms	2 Metal lid support stays.
Document Holder	1 Document area.
Locks	2 Metal locks with keys.
Base	Base with movable dividers.
Cerniere	3 Metal hinges for maximum strength.
Nameplate	Name plate.

ATOMIK215

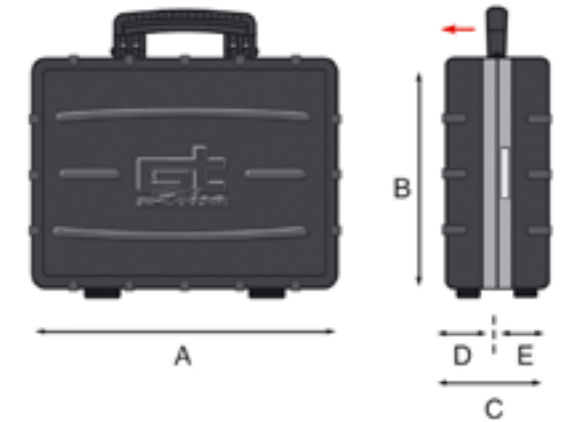

ATOMIK215 PEL/PTS/PSS					
DIMENSIONS (mm)	A	B	C	D	E
INTERNAL	465	354	208.5	90.5	118
EXTERNAL	479	408	217		
Dimensional Tolerance	+/-1.5% from nominal dimensions				



ACCESSORIES								
	WL01	WL02	WL03	WL04	WL05	FOAM ATOMIK	LOCK ATOMIK	PAN ATOMIK
Atomik215 PEL	■	■	■	■	■	■	■	■
Atomik215 PTS	■	■	■	■	■	■	■	■
Atomik215 PSS	■	■	■	■	■	■	■	

✓ Availability of all spare parts.



ATOMIK215 PEL

- EAN: 8024482015668
- 1 Tool panel with elastic straps on both sides
- 1 Tool panel with elastic straps on one side
- 2 metal locks with keys
- Document pocket
- Weight kg 4.95
- Load capacity kg 25.00



ATOMIK215 PTS

- EAN: 8024482015651
- 1 Tool panel with FLEXI POUCHES™ pockets on two sides
- 1 Tool panel with FLEXI POUCHES™ pockets on one side
- 2 metal locks with keys
- Document pocket
- Weight kg 4.95
- Load capacity kg 25.00



ATOMIK215 PSS

- EAN: 8024482015675
- 1 Tool panel with PSS™ system on both sides
- 1 Tool panel with PSS™ system on one side
- 2 metal locks with keys
- Document pocket
- Weight kg 5.35
- Load capacity kg 25.00



CORROSION PROOF

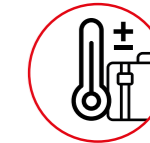
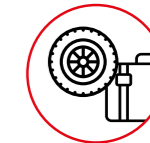

SHOCK PROOF

HIGH & LOW
TEMPERATURE PROOFWHEELS & TELESCOPIC
HANDLE - TROLLEY

ATOMIK WH

Reliable, lightweight and easy to carry

Atomik WH professional trolley is the choice of professionals who need **safety, durability** and **organization**, while also valuing **comfort during their work**.

Made of **thick, injection-moulded polypropylene**, it provides reliable protection against **impacts, corrosive substances and extreme temperatures**.



ATOMIK WH

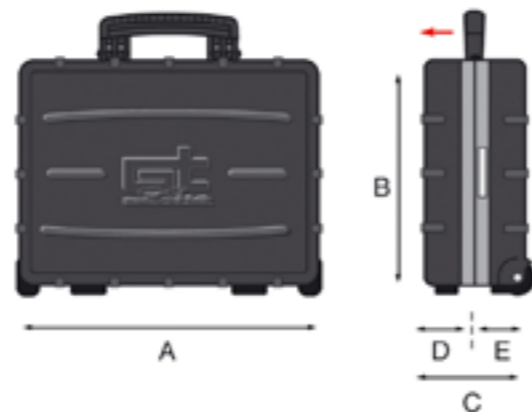

ATOMIK WH PEL/PTS/PSS					
DIMENSIONS (mm)	A	B	C	D	E
INTERNAL	465	354	244.5	90.5	154
EXTERNAL	477	408	257.5		
Dimensional Tolerance	+/-1.5% from nominal dimensions				



TECHNICAL FEATURES

Handles	1 Ergonomic handle with rubber coating. 1 Telescopic handle.
Arms	2 Metal lid support stays.
Document Holder	1 Document area.
Locks	2 metal locks with keys.
Base	Base with removable and adjustable dividers.
Hinges	3 Metal hinges for maximum strength.
Nameplate	Name plate.
Wheels	Wheels with ball bearings.

ACCESSORIES								
	WL01	WL02	WL03	WL04	WL05	FOAM ATOMIK	LOCK ATOMIK	PAN ATOMIK
Atomik WH PEL	■	■	■	■	■	■	■	■
Atomik WH PTS	■	■	■	■	■	■	■	■
Atomik WH PSS	■	■	■	■	■	■	■	■

ATOMIK WH

ATOMIK WH PEL



- EAN: 8024482016436
- 1 Tool panel with elastic straps on both sides
- 1 Tool panel with elastic straps on one side
- 2 Metal locks with keys
- Document pocket
- Weight kg 6.15
- Load capacity kg 25.00



ATOMIK WH PTS



- EAN: 8024482016429
- 1 Tool panel with FLEXI POUCHES™ pockets on both sides
- 1 Tool panel with FLEXI POUCHES™ pockets on one side
- 2 Metal locks with keys
- Document pocket
- Weight kg 6.15
- Load capacity kg 25.00



ATOMIK WH PSS



- EAN: 8024482016443
- 1 Tool panel with PSS™ system on both sides
- 1 Tool panel with PSS™ system on one side
- 2 Metal locks with keys
- Document pocket
- Weight kg 6.55
- Load capacity kg 25.00



○ The load capacity is an estimated value based on evenly distributed weight.









GT 44 -19 PTS

Professional water-resistant case

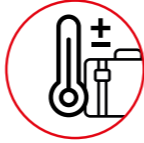
GT 44-19 PTS professional case is the ideal container for professionals who need to **reliably protect their tools and instruments.**

Designed in **high-strength polypropylene**, this medium-sized tool case is **waterproof and resistant to impacts, sand, dust and corrosive agents.**

- 
CORROSION PROOF
- 
SHOCK PROOF
- 
HIGH & LOW TEMPERATURE PROOF
- 
WATER-RESISTANT
- 
AIRPORT HANDLING RESISTANT
- 
STACKABLE

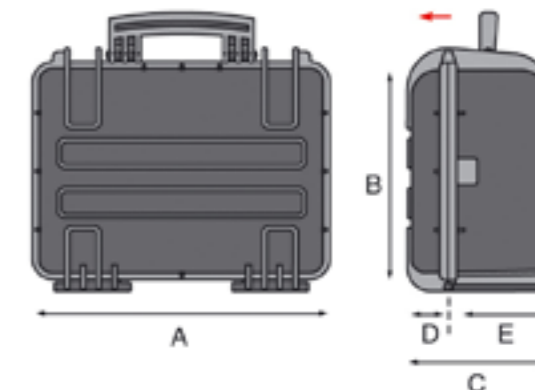

GT 44 - 19 PTS					
DIMENSIONS (mm)	A	B	C	D	E
INTERNAL	445	345	190	47	143
EXTERNAL	480	417	217		
WEIGHT (kg)	6.8				
LOAD CAPACITY (kg)	30.00				
Dimensional Tolerance	+/-1.5% from nominal dimensions				

TECHNICAL FEATURES	
EAN	8024482015569
Splashproof	Water resistant.
Handles	Ergonomic handle with rubber coating.
Arms	Gas pressurised lid supports.
Panels	1 tool panel with FLEXI POUCHES™ pockets on both sides. 1 tool panel with FLEXI POUCHES™ pockets on one side.
Document Holder	Document pocket.
Locks	Lever-release locks. Padlock provision.
Base	Base with removable and adjustable dividers.
Box	2 Component boxes.
Nameplate	Name plate.
Stackable	Yes



ACCESSORIES	WL01	WL02	WL3	WL04	WL05	ADJUSTABLE SHOULDER STRAP	PADLOCK	COMBILOCK	TSA. DIGILOCK
GT 44-19 PTS	■	■	■	■	■	■	■	■	■

✓ Availability of all spare parts.

○ The load capacity is an estimated value based on evenly distributed weight.



GT 48 - 25HL

Heavy-duty professional trolley

GT 48-25HL next-generation professional trolley is the choice of professionals working in demanding environments who require **efficient internal organization**.

This tool trolley is water-resistant, providing complete protection against **water, dust, humidity and corrosive agents**.



CORROSION PROOF



SHOCK PROOF



WATER-RESISTANT

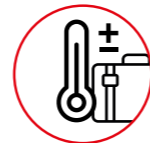

HIGH & LOW TEMPERATURE PROOF



WHEELS & TELESCOPIC HANDLE - TROLLEY



AIRPORT HANDLING RESISTANT

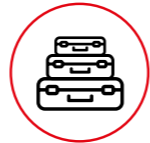

STACKABLE

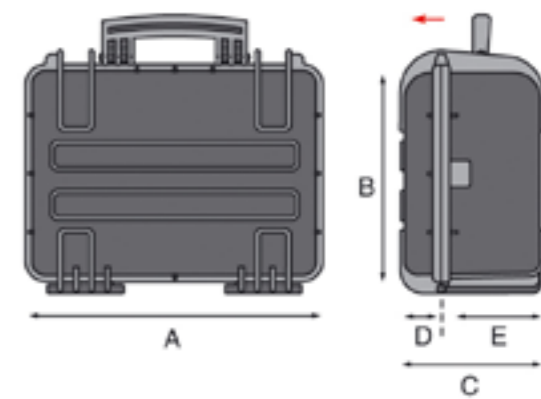

GT 48 - 25HL PEL/PTS/PSS					
DIMENSIONS (mm)	A	B	C	D	E
INTERNAL	480	370	255	50	205
EXTERNAL	520	439	276		
Dimensional Tolerance	+/-1.5% from nominal dimensions				

TECHNICAL FEATURES

Splashproof	Water resistant.
Handles	Ergonomic handle with rubber grip. 1 Telescopic handle.
Arms	Gas-powered lid support arms.
Wheels	2 Wheels with bearings.
Document Holder	Document pocket.
Material	Polypropylene.
Base	Base with high-stability modular dividers.
Hinges	Hinges featuring corrosion resistant pins.
Stackable	Yes



ACCESSORIES	WL01	WL02	WL03	WL04	WL05	PADLOCK	COMBILOCK	TSA. DIGILOCK
	GT 48-25HL PEL	■	■	■	■	■	■	■
GT 48-25HL PTS	■	■	■	■	■	■	■	■
GT 48-25HL PSS	■	■	■	■	■	■	■	■

✓ Availability of all spare parts.



GT 48 - 25HL PEL

- EAN: 8024482191621
- 2 Tool holder panels with elastic bands
- Document pocket
- Weight kg 8.99
- Load capacity kg 35.00



GT 48 - 25HL PTS

- EAN: 8024482191645
- 2 Tool panels with FLEXI POUCHES™ pockets
- Document pocket
- Weight kg 9.09
- Load capacity kg 35.00



GT 48 - 25HL PSS

- EAN: 8024482191638
- 2 Tool panels with PSS™ system
- Document pocket
- Weight kg 9.39
- Load capacity kg 35.00



CORROSION PROOF



SHOCK PROOF

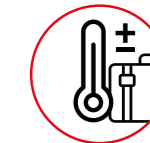
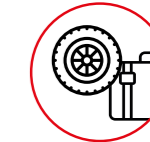
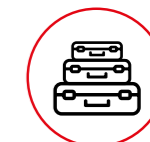

WATER-RESISTANT

HIGH & LOW
TEMPERATURE PROOFWHEELS & TELESCOPIC
HANDLE - TROLLEYAIRPORT HANDLING
RESISTANT

STACKABLE

GT 52 - 21

Large-capacity, water-resistant professional trolley

GT 52-21 professional trolley is a high-performance container designed to deliver **outstanding reliability in critical conditions**. Hermetically sealed and **water-resistant**, it provides **complete protection for tools and equipment against moisture, sand and dust**.

Thanks to its **large capacity**, telescopic handle and **integrated wheels**, this tool case is also ideal for air travel and everyday mobile use.

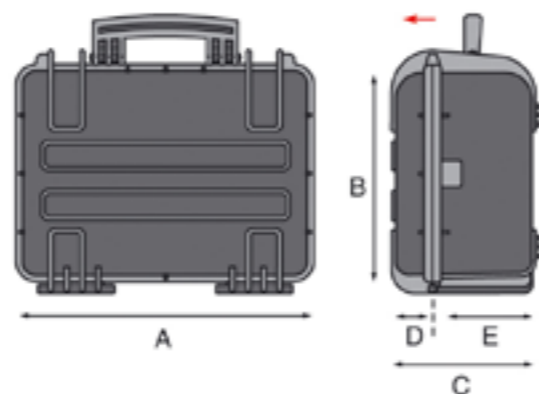

GT 52 - 21 PEL/PTS/PSS					
DIMENSIONS (mm)	A	B	C	D	E
INTERNAL	521.8	284.3	205	55	150
EXTERNAL	550	351	225		
Dimensional Tolerance	+/-1.5% from nominal dimensions				

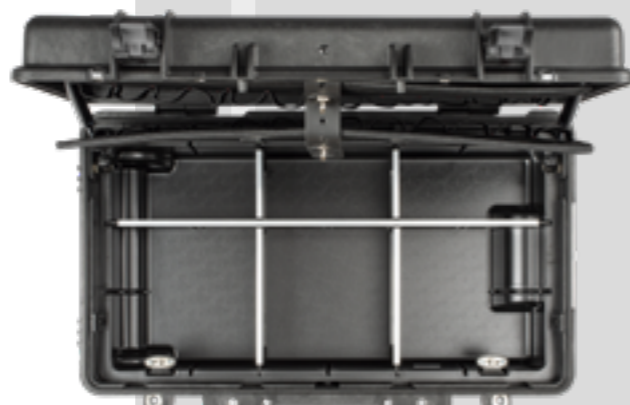

TECHNICAL FEATURES	
Splashproof	Water resistant.
Handles	1 Ergonomic handle with rubber coating. 1 Telescopic handle.
Arms	Gas pressurised lid supports.
Wheels	Self-lubricating wheels.
Document Holder	Document pocket.
Base	Base with removable and adjustable dividers.
Nameplate	Name plate.
Locks	Lever-release locks. Padlock provision.
Stackable	Yes

ACCESSORIES	WL01	WL02	WL03	WL04	WL05	PADLOCK	COMBILOCK	TSA-DIGILOCK	BACKPACK CABIN
	GT 52-21 PEL	■	■	■	■	■	■	■	■
GT 52-21 PTS	■	■	■	■	■	■	■	■	■
GT 52-21 PSS	■	■	■	■	■				■



GT 52 - 21 PEL

- EAN: 8024482184302
- 1 Tool panel with elastic straps on both sides
- 1 Tool panel with elastic straps on one side
- Document pocket
- Weight kg 6.84
- Load capacity kg 30.00



GT 52 - 21 PTS

- EAN: 8024482184326
- 1 Tool panel with FLEXI POUCHES™ pockets on both sides
- 1 Tool panel with FLEXI POUCHES™ pockets on one side
- Document pocket
- Weight kg 6.84
- Load capacity kg 30.00



GT 52 - 21 PSS

- EAN: 8024482184319
- 1 PSS™ Tool panel on two sides
- 1 PSS™ Tool panel on one side
- Document pocket
- Weight kg 7.24
- Load capacity kg 30.00

○ The load capacity is an estimated value based on evenly distributed weight.









GT 53 - 26 PEL

Professional trolley: great organization and capacity in a strong case

GT 53-26 PEL professional trolley is a **durable and spacious** professional container.

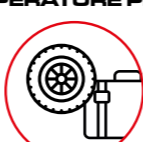
Made of rugged polypropylene, this trolley provides **complete protection even in the most demanding applications.**

- 
CORROSION PROOF
- 
SHOCK PROOF
- 
WATER-RESISTANT
- 
HIGH & LOW TEMPERATURE PROOF
- 
WHEELS & TELESCOPIC HANDLE - TROLLEY
- 
AIRPORT HANDLING RESISTANT
- 
STACKABLE

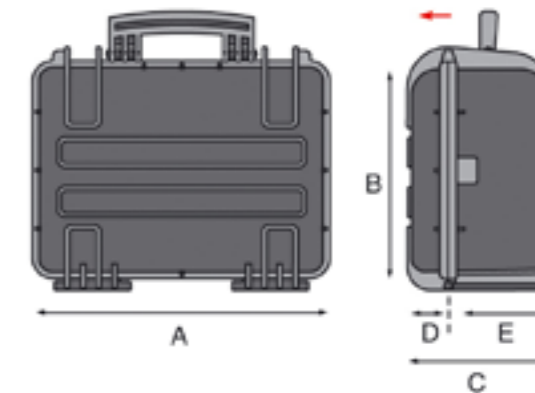

GT 53 - 26 PEL					
DIMENSIONS (mm)	A	B	C	D	E
INTERNAL	538	405	250	60	190
EXTERNAL	627	474.5	292		
WEIGHT (kg)	13.2				
LOAD CAPACITY (kg)	35.00				
Dimensional Tolerance	+/-1.5% from nominal dimensions				

TECHNICAL FEATURES	
EAN	8024482180809
Splashproof	Water resistant.
Handles	1 Ergonomic handle with rubber coating. 1 Telescopic handle with quick lock/unlock system.
Arms	Gas pressurised lid supports.
Panels	1 tool panel with elastic bands on two sides. 2 tool panels with elastic bands on one side.
Document Holder	Document pocket.
Locks	Lever-release locks. Padlock provision and steel reinforcements at the fastening points.
Base	Base with removable and adjustable dividers.
Hinges	Hinges featuring corrosion-resistant pins.
Stackable	Yes
Nameplate	Name plate.
Wheels	2 Self-lubricating wheels.





ACCESSORIES	WL01	WL02	WL03	WL04	WL05	PADLOCK	TSA-DIGILOCK	COMBILOCK
	GT 53-26 PEL	■	■	■	■	■	■	■

✓ Availability of all spare parts.

○ The load capacity is an estimated value based on evenly distributed weight.



- 
CORROSION PROOF
- 
SHOCK PROOF
- 
HIGH & LOW TEMPERATURE PROOF

BOXER

Lightweight and easy to carry

Boxer cases represent the **perfect balance between lightness and strength**, ideal for professionals seeking a **reliable and practical container**. Despite their **compact size**, they offer **generous capacity** and outstanding ease of use.



TECHNICAL FEATURES PEL/PTS/CYBER	
Handles	Handle with rubber grip.
Arms	Metal lid support stay.
Document Holder	Document compartment.
Locks	Locks with key.
Base	Thermoformed base with compartments.
Box	2 Component boxes.
Material	Polypropylene.

ACCESSORIES					
	WL01	WL02	WL03	WL04	WL05
Boxer PEL	■	■	■	■	■
Boxer PTS	■	■	■	■	■
Cyber Boxer	■	■	■	■	■

✓ Availability of all spare parts.

BOXER

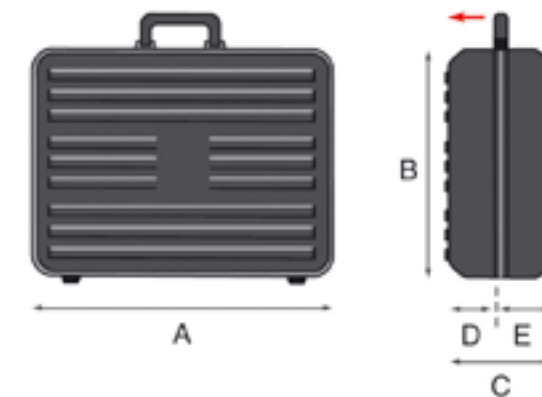

BOXER PEL/PTS/CYBER					
DIMENSIONS (mm)	A	B	C	D	E
INTERNAL	429	341	154	75.5	78.5
EXTERNAL	451	399	164		
Dimensional Tolerance	+/-1.5% from nominal dimensions				



**BOXER PEL**

- EAN: 8024482004006
- 1 Tool panel with elastic straps on two sides
- 1 Tool panel with elastic straps on one side
- Document pocket
- Weight kg 4.10
- Load capacity kg 20.00

**BOXER PTS**

- EAN: 8024482004013
- 1 Tool panel with FLEXI POUCHES™ pockets on both sides
- 1 Tool panel with FLEXI POUCHES™ pockets on one side
- Document pocket
- Weight kg 4.20
- Load capacity kg 20.00

**CYBER BOXER**

- EAN: 8024482003009
- Rigid notebook tray with adjustable straps for secure fastening
- Document pocket
- Base with foam precubed
- Adjustable shoulder strap
- Weight kg 4.10
- Load capacity kg 20.00



CORROSION PROOF

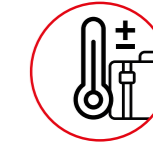
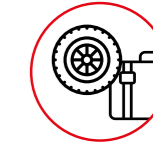

SHOCK PROOF

HIGH & LOW
TEMPERATURE PROOFWHEELS & TELESCOPIC
HANDLE - TROLLEY**BOXER WH****Designed for comfort and easy transport**

Boxer WH trolleys are an **essential ally for professionals who work on the move**. Made of injection-moulded polypropylene with an aluminium profile, they are designed for professionals who need a **reliable and functional trolley**.

BOXER WH

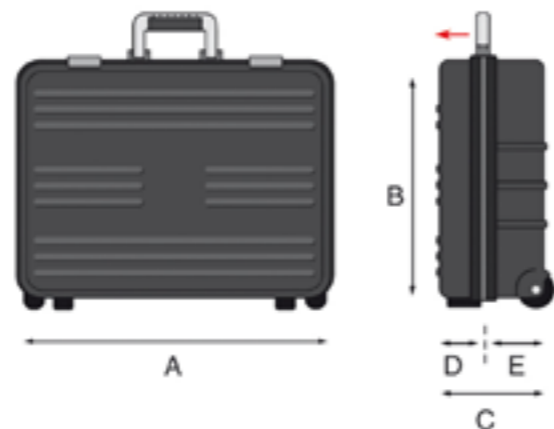

BOXER WH PEL/PTS					
DIMENSIONS (mm)	A	B	C	D	E
INTERNAL	429	341	190	75.5	114.5
EXTERNAL	451	398.8	200		
Dimensional Tolerance	+/-1.5% from nominal dimensions				



TECHNICAL FEATURES	
Wheels	Wheels with ball bearings and side bumpers.
Handles	1 Ergonomic handle with rubber coating. 1 Telescopic handle.
Arms	Metal lid support stay.
Document Holder	Document compartment.
Locks	Side locks with key.
Base	Base with movable dividers.
Box	2 Component boxes.
Material	Polypropylene.

ACCESSORIES	WL01	WL02	WL03	WL04	WL05
	Boxer WH PEL	■	■	■	■
Boxer WH PTS	■	■	■	■	■

BOXER WH



BOXER WH PEL

- EAN: 8024482175652
- 1 Tool panel with elastic straps on two sides
- 1 Tool panel with elastic straps on one side
- Document compartment
- Weight kg 5.15
- Load capacity kg 20.00





BOXER WH PTS

- EAN: 8024482175669
- 1 Tool panel with FLEXI POUCHES™ pockets on both sides
- 1 Tool panel with FLEXI POUCHES™ pockets on one side
- Document compartment
- Weight kg 5.17
- Load capacity kg 20.00



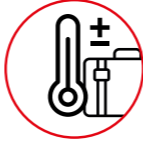

-  CORROSION PROOF
-  SHOCK PROOF
-  HIGH & LOW TEMPERATURE PROOF



REVO21

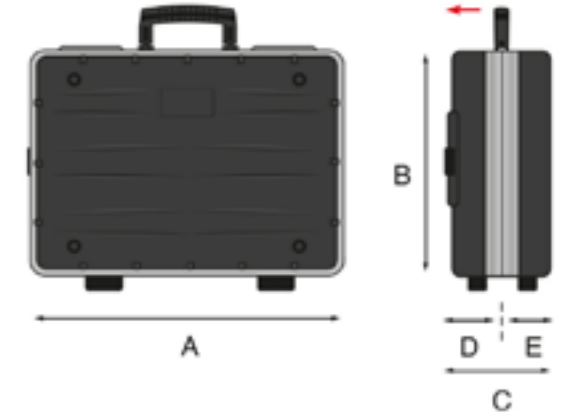

REVO21 PEL/PTS					
DIMENSIONS (mm)	A	B	C	D	E
INTERNAL	451.5	321.5	198.5	85.5	113
EXTERNAL	465.7	378	212.7		
Dimensional Tolerance	+/-1.5% from nominal dimensions				

TECHNICAL FEATURES	
Handles	1 Ergonomic handle with rubber coating.
Document Holder	Document compartment.
Locks	2 Locks with key.
Base	Adjustable divider base.
Hinges	3 Rear hinges with lid holder.
Profile	Strong aluminum profile.



REVO21

Lightweight and designed for comfortable transport

REVO21 professional cases feature an **innovative design** developed to ensure **lightness, strength and flexibility** in any working situation.

ACCESSORIES					
	WL01	WL02	WL03	WL04	WL05
Revo21 PEL	■	■	■	■	■
Revo21 PTS	■	■	■	■	■

✓ Availability of all spare parts.



REVO21 PEL

- EAN: 8024482187228
- 1 Tool panel with elastic straps on two sides
- 1 Tool panel with elastic straps on one side
- Document compartment
- Weight kg 4.19
- Load capacity kg 20.00



REVO21 PTS

- EAN: 8024482187235
- 1 tool panel with FLEXI POUCHES™ pockets on both sides
- 1 tool panel with FLEXI POUCHES™ pockets on one side
- Document compartment
- Weight kg 4.29
- Load capacity kg 20.00



CORROSION PROOF

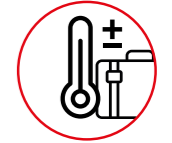

SHOCK PROOF

HIGH & LOW
TEMPERATURE PROOFWHEELS & TELESCOPIC
HANDLE - TROLLEY

REVO21 WH

Lightweight and easy to transport

REVO21 WH professional trolleys combine the features of a tool case with the **practicality of a trolley, ensuring maximum efficiency** even during frequent travel.

REVO21 WH

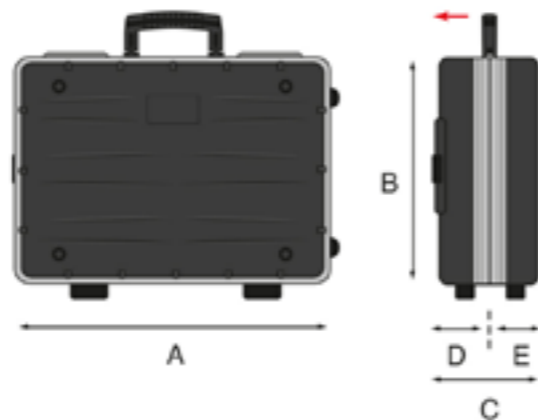

REVO21 WH PEL/PTS					
DIMENSIONS (mm)	A	B	C	D	E
INTERNAL	451.5	321.5	223.5	85.5	138
EXTERNAL	474.4	377.9	242.7		
Dimensional Tolerance	+/-1.5% from nominal dimensions				



TECHNICAL FEATURES	
Wheels	2 Wheels with bearings.
Handles	1 Ergonomic handle with rubber coating. 1 Telescopic handle.
Arms	Lid support arm.
Document Holder	Document compartment.
Locks	2 Side locks with key.
Base	Adjustable divider base.
Hinges	3 Rear hinges with lid holder.

ACCESSORIES	WL01	WL02	WL03	WL04	WL05
	Revo21 WH PEL	■	■	■	■
Revo21 WH PTS	■	■	■	■	■

REVO21 WH

REVO21 WH PEL



- EAN: 8024482187259
- 1 Tool panel with elastic straps on two sides
- 1 Tool panel with elastic straps on one side
- Document compartment
- Weight kg 5.07
- Load capacity kg 20.00







REVO21 WH PTS



- EAN: 8024482187242
- 1 Tool panel with FLEXI POUCHES™ pockets on both sides
- 1 tool panel with FLEXI POUCHES™ pockets on one side
- Document compartment
- Weight kg 5.17
- Load capacity kg 20.00



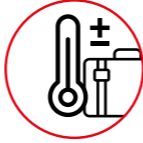

- 
ALUMINIUM SHELL
- 
SHOCK PROOF
- 
HIGH & LOW TEMPERATURE PROOF
- 
CORROSION PROOF

R7/TOP & ALC/170

Design, strength and practicality in aluminium

R7/TOP and ALC/170 professional cases represent **excellence in the world of professional aluminium** tool cases. Made of high-thickness aluminium, they combine refined design, maximum strength and meticulous attention to detail.

TECHNICAL FEATURES		
	R7/TOP	ALC/170
EAN	8024482004396	8024482004327
Handles	Chrome handle with rubber grip.	Chrome handle with rubber grip.
Arms	Metal lid support stays with safety spring pawl.	2 Metal lid support stays with safety spring pawl.
Panels	1 Tool panel with elastic straps on two sides. 1 Tool panel with elastic straps on one side.	1 Tool panel with elastic straps on two sides. 1 Tool panel with elastic straps on one side.
Document Holder	Double document pocket.	Document pocket.
Locks	2 Chrome steel locks. 1 Central combination lock.	2 Chrome steel locks.
Base	Thermoformed base with storage compartments, featuring 3 fixed sections including one drill holder.	Thermoformed base with compartments, featuring 3 fixed slots including one for a drill. Base with removable and adjustable dividers.
Hinges	3 Metal hinges for maximum strength.	3 Metal chromed high thickness hinges.
Box	2 Component boxes.	2 Component boxes.
Material	Case body cold-formed from aluminum sheet.	Scratch-resistant aluminum body.
Profile	High-thickness aluminum profile.	Aluminum profile.
Shoulder Strap		1 Shoulder strap.

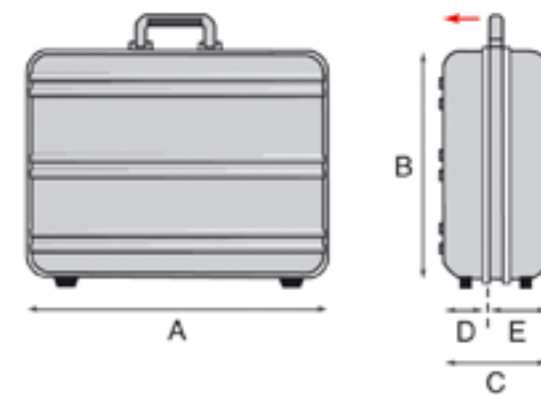

R7/TOP					
DIMENSIONS (mm)	A	B	C	D	E
INTERNAL	473	353	180.1	77.1	103
EXTERNAL	482	396.5	187.7		
WEIGHT (kg)	5.60				
LOAD CAPACITY (kg)	20.00				
Dimensional Tolerance	+/-1.5% from nominal dimensions				

ALC/170

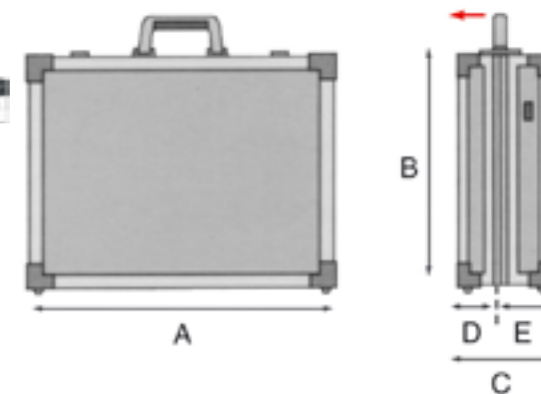



ALC/170					
DIMENSIONS (mm)	A	B	C	D	E
INTERNAL	436	329	177	79	98
EXTERNAL	454	377	186		
WEIGHT (kg)	6.04				
LOAD CAPACITY (kg)	20.00				
Dimensional Tolerance	+/-1.5% from nominal dimensions				

ACCESSORIES	WL01	WL02	WL03	WL04	WL05
	R7/TOP	■	■	■	■
ALC/170	■	■	■	■	■

✓ Availability of all spare parts.

○ The load capacity is an estimated value based on evenly distributed weight.

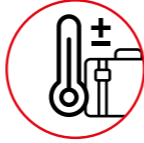

- 
CORROSION PROOF
- 
SHOCK PROOF
- 
HIGH & LOW TEMPERATURE PROOF

FLASH

Simple and durable

Flash 2 professional case is the ideal solution for those seeking the **perfect balance between quality, functionality and price**. Built with injection-moulded ABS walls and reinforced with aluminium profiles, **this tool case is engineered to stand the test of time**.

TECHNICAL FEATURES		
	FLASH 2 PEL	FLASH 2 PTS
EAN	8024482182599	8024482182612
Handles	Handle with rubber grip.	Handle with rubber grip.
Panels	1 Tool panel with elastic straps on two sides. 1 Tool panel with elastic straps on one side.	1 Tool panel with FLEXI POUCHES™ pockets on both sides. 1 Tool panel with FLEXI POUCHES™ pockets on one side.
Document Holder	Document pocket.	Document pocket.
Locks	2 Locks with key.	2 Locks with key.
Base	Bottom with removable dividers.	Bottom with removable dividers.
Hinges	2 Hinges with lid support.	2 Hinges with lid holder.
Material	Abs.	Abs.
Profile	Aluminum profile.	Aluminum profile.



FLASH

FLASH 2 PEL

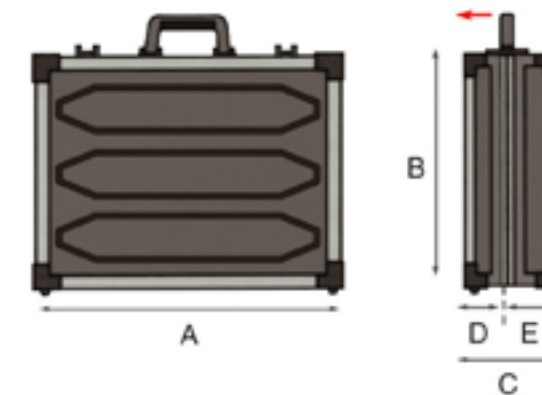

FLASH 2 PEL					
DIMENSIONS (mm)	A	B	C	D	E
INTERNAL	452.6	317.6	158	62	96
EXTERNAL	465.9	373.5	170		
WEIGHT (kg)	4.11				
LOAD CAPACITY (kg)	20.00				
Dimensional Tolerance	+/-1.5% from nominal dimensions				



FLASH 2 PTS

FLASH 2 PTS					
DIMENSIONS (mm)	A	B	C	D	E
INTERNAL	452.6	317.6	158	62	96
EXTERNAL	465.9	373.5	170		
WEIGHT (kg)	4.15				
LOAD CAPACITY (kg)	20.00				
Dimensional Tolerance	+/-1.5% from nominal dimensions				

ACCESSORIES					
	WL01	WL02	WL03	WL04	WL05
Flash 2 PEL	■	■	■	■	■
Flash 2 PTS	■	■	■	■	■



CORROSION PROOF



SHOCK PROOF

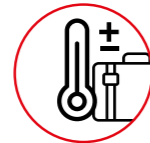

HIGHT & LOW TEMPERATURE PROOF

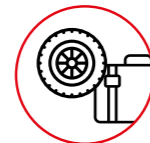

WHEELS & TELESCOPIC HANDLE - TROLLEY

FLASH WH 2 PEL

Simple, durable and designed for easy transport

Flash WH 2 professional trolley by GT Line is the ideal choice for those seeking a tool case that is **durable, versatile and easy to transport.**

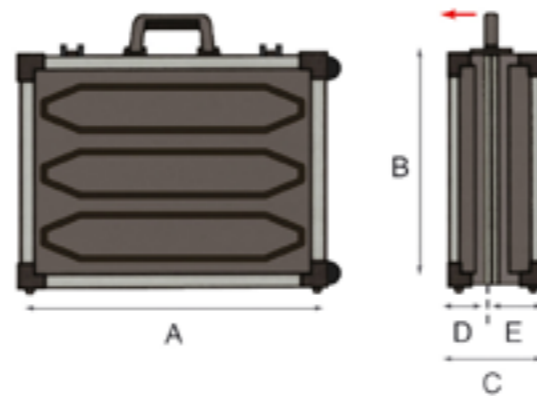

FLASH WH 2 PEL					
DIMENSIONS (mm)	A	B	C	D	E
INTERNAL	452.6	317.6	192	62	130
EXTERNAL	477.5	373.5	218.5		
WEIGHT (kg)	5.12				
LOAD CAPACITY (kg)	20.00				
Dimensional Tolerance	+/-1.5% from nominal dimensions				

TECHNICAL FEATURES	
EAN	8024482185187
Handles	Handle with rubber grip.
Panels	1 Tool panel with elastic straps on two sides. 1 Tool panel with elastic straps on one side.
Document Holder	Document pocket.
Locks	2 Locks with key.
Hinges	2 Hinges with lid support.
Wheels	2 Rubber wheels.
Profile	Aluminum profile.
Base	Base with dividers.



ACCESSORIES	WL01	WL02	WL03	WL04	WL05
Flash WH 2 PEL	■	■	■	■	■

○ The load capacity is an estimated value based on evenly distributed weight.



CORROSION PROOF



WATER-RESISTANT



SHOCK PROOF



HIGHT & LOW TEMPERATURE PROOF



AIRPORT HANDLING RESISTANT

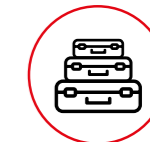

STACKABLE

MUB

Maximum capacity and easy storage

MUB professional models are **multifunctional technical containers**, ideal for professionals working outdoors and in extreme conditions.

Made of injection-moulded polypropylene, **they combine lightness and strength with exceptional load capacity.** MUB containers are **stackable, lightweight** and equipped with ergonomic handles and wheels, ensuring easy transport even on construction sites, in marine environments and in other demanding outdoor sectors.

TECHNICAL FEATURES		
	MUB78	MUB65
EAN	8024482016146	8024482181998
Wheels	Heavy-duty wheels.	Without wheels.
Splashproof	Water resistant.	Water resistant.
Handles	2 Ergonomic side handle. 1 Ergonomic side handle. 1 Front handle bar.	2 Ergonomic side handle. 1 Ergonomic side handle. 1 Front handle bar.
Locks	Padlock provision.	Padlock provision.
Nameplate	Name plate.	Name plate.
Stackable	Yes	Yes



MUB78

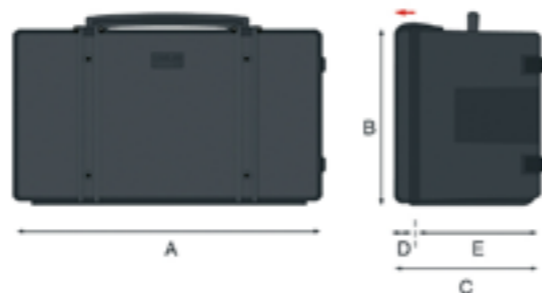

MUB78					
DIMENSIONS (mm)	A	B	C	D	E
INTERNAL	780	410	330	50	280
EXTERNAL	806	467	349		
WEIGHT (kg)	6.52				
LOAD CAPACITY (kg)	50.00				
Dimensional Tolerance	+/-1.5% from nominal dimensions				

ACCESSORIE
KIT TRAY MUB



MUB65





















MUB65					
DIMENSIONS (mm)	A	B	C	D	E
INTERNAL	653	340	312	65	247
EXTERNAL	677	404	331		
WEIGHT (kg)	4.39				
LOAD CAPACITY (kg)	30.00				
Dimensional Tolerance	+/-1.5% from nominal dimensions				













ACCESSORIES	WL01	WL02	WL03	WL04	WL05	PADLOCK	COMBILOCK	TSA-DIGILOCK	FOAM MUB78	KIT TRAY MUB
MUB78	■	■	■	■	■	■	■	■	■	■
MUB65	■	■	■	■	■	■	■	■		■

○ The load capacity is an estimated value based on evenly distributed weight.



 TECHNICAL TABLE		INTERNAL DIMENSIONS (mm)			LID	BASE	EXTERNAL DIMENSIONS (mm)			WEIGHT
		Lenght	Width	Height	Height	Width	Lenght	Width	Height	KG
ATOMIK NEO M		468	351	208	78	130	485	419	222	PEL 6.00 PTS 6.10 PSS 6.60
ATOMIK NEO WH		M 468 L 468	M 351 L 351	M 245 L 267	M 78 L 100	M 167 L 167	M 485 L 485	M 419 L 419	M 265 L 287	PEL M 7.30 PTS M 7.40 PSS M 7.90 PEL L 7.70 PTS L 7.80 PSS L 8.40
V-ROCK TURTLE		470	385	330	137	193	539	446	385	PEL 8.80 PTS 8.90 PSS 9.20
ROCK TURTLE		470	390	300	106	194	517	453	349	PEL 8.52 PTS 8.62 PSS 8.92
NEW MEGA WHEELS		473	369	170	68	102	564	455	249	PEL 7.73 PTS 8.13
BOMBER 170 PEL		429	326	174	74	100	477	408	211	PEL 5.37
ATOMIK215		465	354	208.5	90.5	118	479	408	217	PEL 4.95 PTS 4.95 PSS 5.35
ATOMIK WH		465	354	244.5	90.5	154	477	408	257.5	PEL 6.15 PTS 6.15 PSS 6.55
GT 44-19 PTS		445	345	190	47	143	480	417	217	PTS 4.05
GT 48-25HL		480	370	255	50	205	520	439	276	PEL 8.99 PTS 9.09 PSS 9.39
GT 52-21		521.8	284.3	205	55	150	550	351	225	PEL 6.84 PTS 6.84 PSS 7.24
GT 53-26 PEL		538	405	250	60	190	627	474.5	292	PEL 9.12
BOXER		429	341	154	75.5	78.5	451	399	164	PEL 4.10 PTS 4.20 CYBER 4.10
BOXER WH		429	341	190	75.5	114.5	451	398.8	200	PEL 5.15 PTS 5.17
REVO21		451.5	321.5	198.5	85.5	113	465.7	378	212.7	PEL 4.19 PTS 4.29
REVO21 WH		451.5	321.5	223.5	85.5	138	474.4	377.9	242.7	PEL 5.07 PTS 5.17
R7/TOP		473	353	180.1	77.1	103	482	396.5	187.7	5.60
ALC/170		436	329	177	79	98	454	377	186	6.04
FLASH		452.6	317.6	158	62	96	465.9	373.5	170	PEL 4.11 PTS 4.15
FLASH WH		452.6	317.6	192	62	130	477.5	373.5	218.5	PEL 5.12
MUB		MUB78 780 MUB65 653	MUB78 410 MUB65 340	MUB78 330 MUB65 312	MUB78 50 MUB65 65	MUB78 280 MUB65 247	MUB78 806 MUB65 677	MUB78 467 MUB65 404	MUB78 349 MUB65 331	MUB78 6.52 MUB65 4.39

LOAD CAPACITY	SHELL MATERIAL	VERSIONS			LOCKS											P.	
		PEL	PTS	PSS	KEY	TSA	PAD-LOCK										N°
																	
20	PP	■	■	■	■			■	■	■							27
25	PP	■	■	■	M		L	■	■	■	■						30
40	HDPE	■	■	■		■		■	■	■	■	■	■	■			34
40	HDPE	■	■	■		■		■	■	■	■	■	■	■			37
35	HDPE	■	■			■		■	■	■	■	■	■				40
30	HDPE	■				■		■	■	■		■					43
25	PP	■	■	■				■	■	■							44
25	PP	■	■	■				■	■	■	■						47
30	PP		■					■	■	■	■	■	■	■			50
35	PP	■	■	■				■	■	■	■	■	■	■	■		52
30	PP	■	■	■				■	■	■	■	■	■	■			55
35	PP	■						■	■	■	■	■	■	■			58
20	PP	■	■					■	■	■							60
20	PP	■	■					■	■	■	■						63
20	PP	■	■					■	■	■	■						66
20	PP	■	■					■	■	■	■						69
20	ALU							LOCK + COMBI	■	■	■				■		72
20	ABS	■	■					■	■	■	■	■					74
											■						76
MUB78 50 MUB65 30	PP									■	■	■	■	■	■		77

WORK
by **gt** *Line*

brand of **gt** *Line*
group



NEW!
Monolith Line





MONOLITH CROSS LT40

New energy for professional versatility

Monolith Cross LT40 is the Work Line by GT trolley featuring an innovative design, engineered for field professionals who demand maximum **functionality** and **organization**. The large 120 mm treaded wheels, rigid base and backpack-carry setup provide **freedom of movement** and **outstanding durability in any working environment**.

With 46 pockets, 6 elastic loops, a double removable tool panel, it delivers **superior storage capacity and organization** for up to 66 tools.



MONOLITH CROSS LT40 trolley

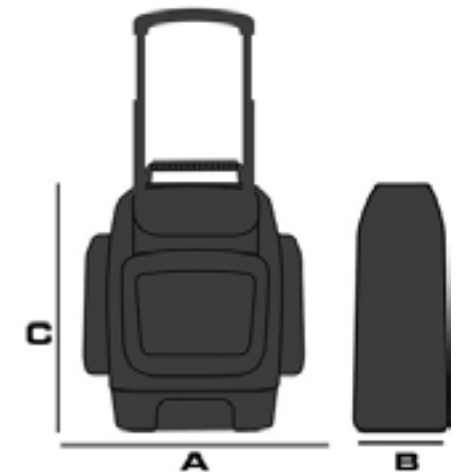

MONOLITH CROSS LT40					
DIMENSIONS (mm)	A	B	C	D	E
EXTERNAL	370	300	560		
WEIGHT (kg)	6.22				
Dimensional Tolerance	+/-1.5% from nominal dimensions				

TECHNICAL FEATURES	
EAN	8024482193762
Volume	40L Capacity.
Wheels	Large Ø 120 mm treaded wheels.
Trolley	Trolley system convertible for backpack carry.
Handle	"Memory foam" rubber handle.
Back	Internal back panel can hold 3 WL small parts boxes. Ergonomic padded backrest with attachment points for shoulder straps (included).
Panels	Large internal compartment with double removable tool panel with handle.
Side Pockets	Document and laptop pocket. 2 external auxiliary pockets with "molle system". 46 pockets and 6 elastic loops for a total transport of 66 tools.
Front Compartment	Semi-rigid EVA front compartment with accessory pocket and internal ZIP access.
Base	Rigid plastic base.



ACCESSORIES	WL01	WL02	WL03	WL04	WL05
	Monolith Cross	■	■	■	■



MONOLITH LT20
backpacks

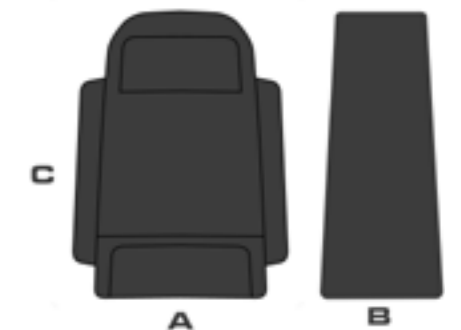

MONOLITH LT20					
DIMENSIONS (mm)	A	B	C	D	E
EXTERNAL	370	240	480		
WEIGHT (kg)	2.34				
Dimensional Tolerance	+/-1.5% from nominal dimensions				

MONOLITH LT20

New energy in a backpack designed to stand on its own

Monolith LT20 is the Work Line by GT backpack featuring an **innovative design**, created to deliver **organization, practicality** and **comfort for everyday professional use**.

The **self-standing structure** with protective skid plate, **dual front** and rear access and a **dedicated laptop** and **document compartment** ensure neat storage and quick, efficient operation.

With 26 internal pockets, 6 elastic loops and dedicated accessory compartments, it provides organized storage for up to 44 tools.

TECHNICAL FEATURES	
EAN	8024482193779
Volume	20L Capacity.
Skid Plate	Protective base with feet to guard against impacts, scratches, and dirt.
Self standing	Self-standing design – stays upright at all times.
Panels	Panel features pockets for laptops, documents, and office accessories. Semi-rigid EVA front panel with integrated small parts pocket.
Back	External backrest with ergonomic padding.
Side Pockets	1 Side Pocket: 26 internal tool pockets and 6 elastic bands for a total transport of up to 44 tools.
Handle	1 Ergonomic handle.
Access	Dual access: front and rear openings.

ACCESSORIES	WL01	WL02	WL03	WL04	WL05
Monolith LT20	■	■	■	■	■





MONOLITH LT35

Modern design for a backpack with a reinforced base

Monolith LT35 is a high-resistance work backpack with an innovative design, combining large internal capacity, functionality and comfort.

Designed for technicians, maintenance specialists, and installers, this tool backpack is engineered for the safe and organized transport of **tools, accessories, documents** and **laptops up to 17"**.



MONOLITH LT35 backpacks

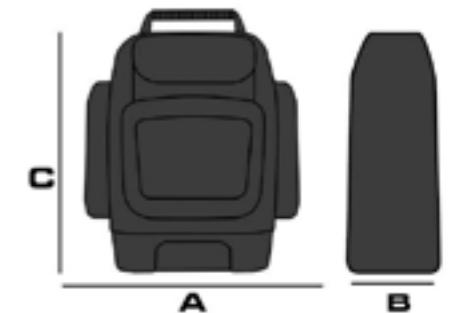

MONOLITH LT35					
DIMENSIONS (mm)	A	B	C	D	E
EXTERNAL	430	270	570		
WEIGHT (kg)	3.80				
Dimensional Tolerance	+/-1.5% from nominal dimensions				

TECHNICAL FEATURES	
EAN	8024482191553
Handles	Large top handle.
Panels	Removable and reversible internal panel Robust tool holders in various sizes. External front and side pockets on both sides. Dual access to the main compartment (front and rear).
Front Panel	Front and rear flip-front panel with 90° opening for easy access.
Back	Back extra padding for maximum comfort as backpack.
Pocket	Rear pass-through pocket for trolley attachment.
Material	Polyester Fabric.
PC Holder	Laptop pocket up to 17".
Base	Large, rigid, shock-absorbent base.

ACCESSORIES	WL01	WL02	WL03	WL04	WL05
Monolith LT35	■	■	■	■	■





TOP 07 R & TOP 10 R

Ultimate functionality and practicality

TOP 07 R professional backpack and TOP 10 R bag are designed to provide **maximum functionality, safety and organization** in the daily work of technicians, installers and maintenance professionals on the move.

TECHNICAL FEATURES		
	TOP 07 R	TOP 10 R
EAN	8024482188775	8024482189192
Handles	Wide padded top handle. Loop for attachment to a trolley handle.	Handle with rubber grip.
Panels	Tool panel with pockets on two sides and lockable zipper. Removable and reversible inner panel.	Main compartment for laptop and cable case. Internal pocket for cellphone. Rear area with tool pockets and elastic straps.
Front Panel	Front and rear flip panels with 90° opening for easy access.	External document pocket.
Back	Back padding for maximum comfort.	
Feet	Four rubber feet on the base.	
Material	Polyester Fabric.	Polyester Fabric.
Shoulder Strap	Adjustable shoulder straps and waist belt.	Adjustable neoprene shoulder strap.
Internal	Internal and external pockets for tools, accessories and documents.	Laptop compartment for up to 13".



TOP 07 R backpacks

TOP 07 R

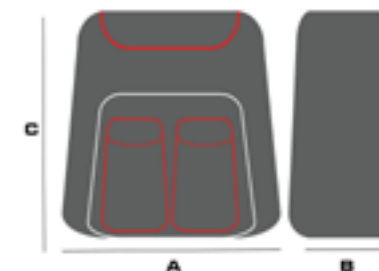

TOP 07 R					
DIMENSIONS (mm)	A	B	C	D	E
EXTERNAL	300	140	400		
WEIGHT (kg)	2.30				
Dimensional Tolerance	+/-1.5% from nominal dimensions				

ACCESSORIES					
	WL01	WL02	WL03	WL04	WL05
Top 07 R	■	■	■	■	■

TOP 10 R tool bags/pc

TOP 10 R



TOP 10 R					
DIMENSIONS (mm)	A	B	C	D	E
EXTERNAL	400	130	310		
WEIGHT (kg)	1.40				
Dimensional Tolerance	+/-1.5% from nominal dimensions				

ACCESSORIES					
	WL01	WL02	WL03	WL04	WL05
Top 10 R	■	■	■	■	■



BAG 07 R
backpacks

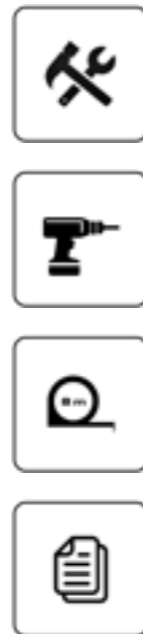

BAG 07 R

**Lightweight and versatile
perfect for professionals on
the move**

Bag 07 R is a **compact tool backpack** featuring multiple external pockets and a **large internal roll-up compartment** equipped with sections for tools and accessories. The **adjustable shoulder** straps make this work backpack comfortable to wear even during long transfers or extended use.

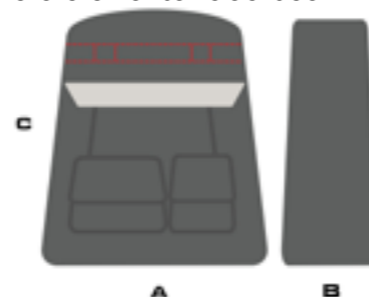

TECHNICAL FEATURES	
EAN	8024482188881
Handles	1 Central handle.
Panels	External pockets of various sizes. Roll-up internal pocket with tool holders.
Locks	Top closure with zipper.
Material	Polyester Fabric.

BAG 07 R					
DIMENSIONS (mm)	A	B	C	D	E
EXTERNAL	310	120	390		
WEIGHT (kg)	0.80				
Dimensional Tolerance	+/-1.5% from nominal dimensions				

ACCESSORIES					
	WL01	WL02	WL03	WL04	WL05
Bag 07 R	■	■	■	■	■

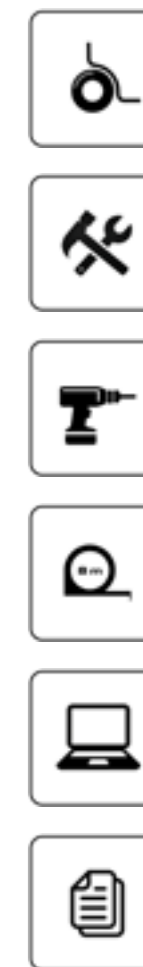

TOOL TROLLEY 01 R

Professional, practical and easy to carry

Tool Trolley 01 R is the ideal solution for professionals looking for a **practical, well-organized and easily transportable tool trolley**.

Equipped with **two reversible panels**, one featuring **tool pockets** and the other **with a padded compartment for laptops up to 15"**, it allows **safe transport of both tools and electronic devices**. Two additional front pockets complete the profile of a perfect tool trolley for professionals working in the field.

TOOL TROLLEY 01 R
trolley

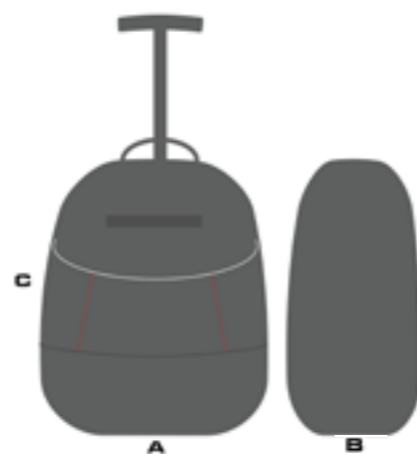

TOOL TROLLEY 01 R					
DIMENSIONS (mm)	A	B	C	D	E
EXTERNAL	360	200	480		
WEIGHT (kg)	4.25				
Dimensional Tolerance	+/-1.5% from nominal dimensions				

TECHNICAL FEATURES	
EAN	8024482188744
Wheels	Two wheels with protection for backpack-style use.
Handles	Integrated handle. Pull-out handle.
Panels	Removable internal tool panel with pockets and elastic bands on both sides. Inner side with fixed pockets and elastic bands.
Document Holder	Front document pocket with elastic pen holders.
PC Holder	Laptop pocket up to 15".
Shoulder Strap	2 Adjustable shoulder straps.
Material	Polyester Fabric.



ACCESSORIES	WL01	WL02	WL03	WL04	WL05
Tool Trolley 01 R	■	■	■	■	■

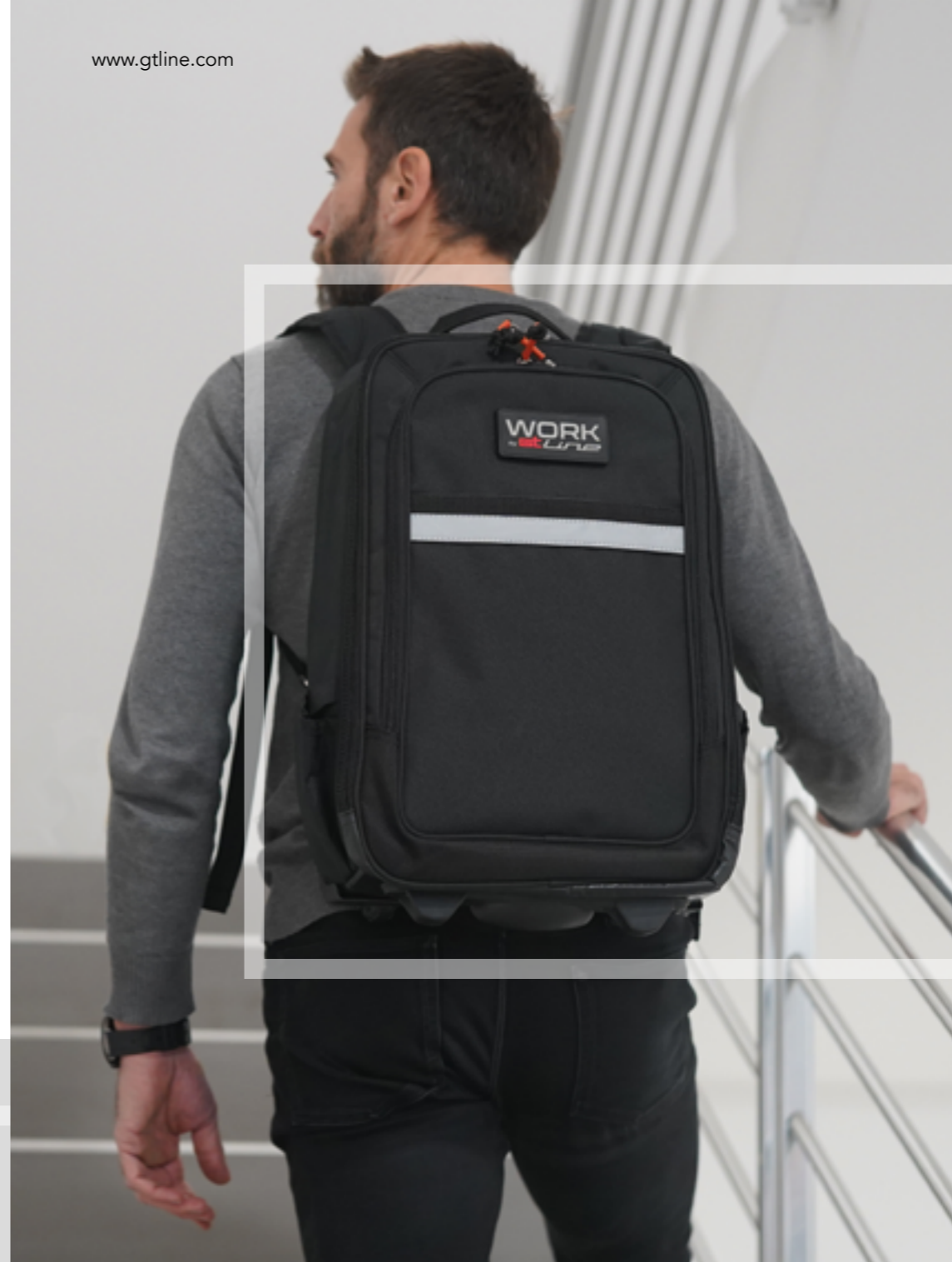

SOFT TROLLEY 01 R
Versatility and practicality

Soft Trolley 01 R is a compact and multifunctional work trolley. Equipped with a **removable tool panel**, adjustable shoulder straps and a **wheel protection system**, it ensures flexibility and comfort in any working situation. It combines the convenience of a professional backpack with the functionality of a tool trolley.



SOFT TROLLEY 01 R
trolley

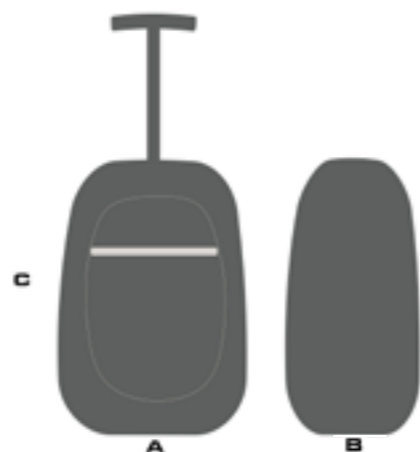

SOFT TROLLEY 01 R					
DIMENSIONS (mm)	A	B	C	D	E
EXTERNAL	310	190	480		
WEIGHT (kg)	2.50				
Dimensional Tolerance	+/-1.5% from nominal dimensions				

TECHNICAL FEATURES	
EAN	8024482188867
Wheels	Equipped with two wheels featuring protective covers to prevent damage when worn as a backpack.
Handles	Integrated handle. Removable handle.
Panels	Removable tool panel with pockets and elastics on both sides. Inner side with fixed pockets and elastics.
Document Holder	Front pocket for documents, equipped with elastic loops for pens and small accessories.
Porta PC	Laptop pocket.
Shoulder Strap	2 Adjustable shoulder straps.
Material	Polyester Fabric.



ACCESSORIES	WL01	WL02	WL03	WL04	WL05
Soft Trolley 01 R	■	■	■	■	■



SOFT PILOT R

Functional design for tools and electronic devices.

Soft Pilot R is a professional tool bag with an intelligent pilot-style design, offering practical vertical access for carrying tools and electronic devices up to 15.6", combining functionality and protection in one compact product.

The removable front compartment transforms into a convenient standalone tool bag, while the numerous pockets, elastic holders and compartments ensure optimal organization for every professional on the move.



SOFT PILOT R
tool bags/pc

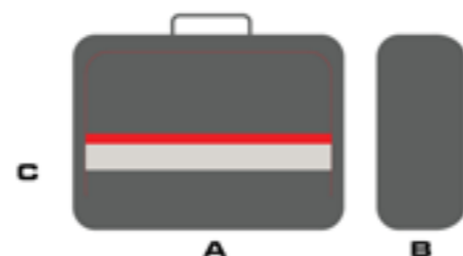

SOFT PILOT R					
DIMENSIONS (mm)	A	B	C	D	E
EXTERNAL	420	205	360		
WEIGHT (kg)	2.10				
Dimensional Tolerance	+/-1.5% from nominal dimensions				



TECHNICAL FEATURES	
EAN	8024482188874
Handles	Integrated handle.
Panels	Front and rear area with elastic straps and tool pockets. Side pockets on both sides. Removable front compartment, convertible into a tool bag.
PC Holder	Vertical access for laptops up to 15.6" and tools.
Material	Polyester Fabric.
Shoulder Strap	Adjustable neoprene shoulder strap.



ACCESSORIES	WL01	WL02	WL03	WL04	WL05
	Soft Pilot R	■	■	■	■

BAG & CASE PTS R
tool bags

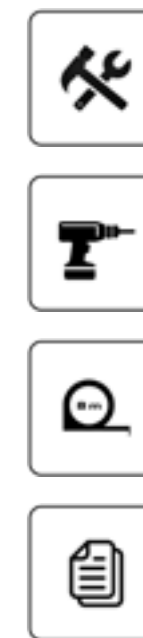

BAG & CASE PTS R
Comfort and functionality

BAG & CASE PTS R tool bag is the ideal solution for professionals seeking the perfect balance between **functionality, durability and comfort.**

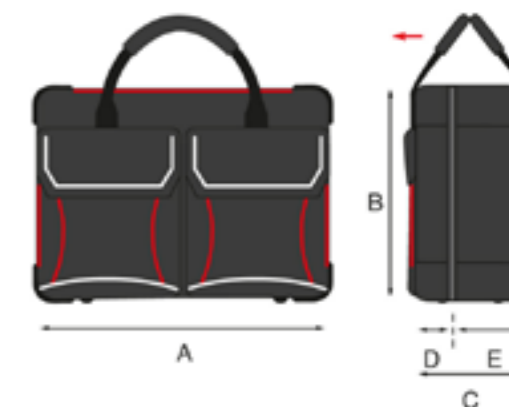

TECHNICAL FEATURES	
EAN	8024482189512
Panels	2 tool panels with FLEXI POUCHES™ pockets.
Document Holder	1 Document pocket.
Locks	Closure zipper for padlock.
Base	Rigid bottom with removable dividers.
Box	2 Component boxes.
Material	Polyester Fabric.
Profile	Reinforced rubber corners.
Shoulder Strap	Adjustable neoprene shoulder strap.

BAG & CASE PTS R					
DIMENSIONS (mm)	A	B	C	D	E
EXTERNAL	455	170	360		
WEIGHT (kg)	4.00				
Dimensional Tolerance	+/-1.5% from nominal dimensions				

ACCESSORIES	WL01	WL02	WL03	WL04	WL05
	Bag & Case PTS R	■	■	■	■



PSS COMPACT BAG R
tool bags



PSS COMPACT BAG R

Compact and functional

PSS Compact Bag is the ideal tool bag for electricians, technicians and maintenance professionals seeking a **compact yet highly functional solution.**

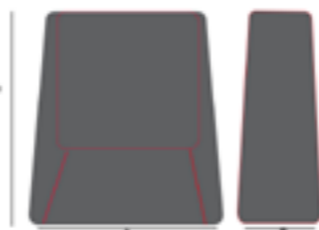

PSS COMPACT BAG R					
DIMENSIONS (mm)	A	B	C	D	E
EXTERNAL	330	110	330		
WEIGHT (kg)	1.50				
Dimensional Tolerance	+/-1.5% from nominal dimensions				

TECHNICAL FEATURES	
EAN	8024482189529
Handles	Integrated handle.
Panels	2 Pull-out tool holder panels with PSS system.
Box	2 Component boxes.
Material	Polyester Fabric.
Shoulder Strap	Adjustable neoprene shoulder strap.

ACCESSORIES	WL01	WL02	WL03
	PSS Compact Bag R	■	■



TOP 04 R | TOP 06 R | TOP 08 L R

Modern design for every professional

TOP 04 R, TOP 06 R and TOP 08 L R are **compact and multifunctional**, designed for demanding professionals who value a **clean, refined design**. They feature **padded pockets** to protect tools, an **adjustable shoulder strap** for easy carrying and a **reinforced shock-resistant base** in the TOP 04 R and TOP 06 R models.

Complete with a document compartment and a removable clipboard folder in the TOP 08 L R version, these bags are ideal for professionals who need to combine organization, protection and a professional image.

TECHNICAL FEATURES			
	TOP 04 R	TOP 06 R	TOP 08 L R
EAN	8024482188904	8024482188911	8024482189208
Handles	Integrated handle.	Integrated handle.	Integrated handle.
Panels	Padded pockets.	Padded pockets.	Removable clipboard folder. Internal tool pockets. External document pocket.
Base	Resistant shockproof rigid bottom.	Resistant shockproof rigid bottom.	
Material	Polyester Fabric.	Polyester Fabric.	Polyester Fabric.
Shoulder Strap	Adjustable neoprene shoulder strap.	Adjustable neoprene shoulder strap.	



TOP 04 R



TOP 04 R					
DIMENSIONS (mm)	A	B	C	D	E
EXTERNAL	410	230	300		
WEIGHT (kg)	1.30				
Dimensional Tolerance	+/-1.5% from nominal dimensions				



TOP 06 R

TOP 06 R					
DIMENSIONS (mm)	A	B	C	D	E
EXTERNAL	515	210	300		
WEIGHT (kg)	1.55				
Dimensional Tolerance	+/-1.5% from nominal dimensions				



TOP 08 L R

TOP 08 L R					
DIMENSIONS (mm)	A	B	C	D	E
EXTERNAL	420	60	300		
WEIGHT (kg)	1.30				
Dimensional Tolerance	+/-1.5% from nominal dimensions				

TOP R tool bags



BAG R

Lightweight, organized, compact

BAG R tool bags are **compact and durable**, ideal for electricians, installers and maintenance technicians. They offer smart tool organization thanks to **multiple pockets, spacious internal compartments and well-designed details for quick and orderly access.**

Equipped with ergonomic handles, an adjustable shoulder strap, secure zip and front clip closures and adjustable shoulder straps in the BAG 07 R model, they **combine lightness and strength** in a practical format, perfect to use alongside professional backpacks or tool cases.

TECHNICAL FEATURES			
	BAG 04 R	BAG 05 R	BAG 06 R
EAN	8024482188942	8024482188966	8024482188959
Handles	Handle for convenient carrying.	Handle for convenient carrying.	Handle for convenient carrying.
Panels	Pockets of various sizes.	Pockets of various sizes.	Pockets of various sizes.
Locks	Top zipper closure.	Front clip closure.	Top zipper closure.
Hookup		Spirit level holder.	
Material	Polyester Fabric.	Polyester Fabric.	Polyester Fabric.
Shoulder Strap		Adjustable neoprene shoulder strap.	Adjustable neoprene shoulder strap.



BAG 04 R



BAG 04 R					
DIMENSIONS (mm)	A	B	C	D	E
EXTERNAL	320	210	240		
WEIGHT (kg)	0.50				
Dimensional Tolerance	+/-1.5% from nominal dimensions				



BAG 05 R

BAG 05 R					
DIMENSIONS (mm)	A	B	C	D	E
EXTERNAL	400	55	310		
WEIGHT (kg)	0.70				
Dimensional Tolerance	+/-1.5% from nominal dimensions				



BAG 06 R

BAG 06 R					
DIMENSIONS (mm)	A	B	C	D	E
EXTERNAL	510	200	270		
WEIGHT (kg)	1.20				
Dimensional Tolerance	+/-1.5% from nominal dimensions				





TOP BELT R/TOP ELECTRA R wearables

TOP BELT R

Practical and versatile

TOP BELT R is a **simple, durable and versatile tool belt**, perfect to combine with the tool pouches and holsters from the Work Line by GT, Top Electra R, Top Drill R, Top Nail R and Top Tape Plus R series.

TOP BELT R					
DIMENSIONS (mm)	A	B	C	D	E
EXTERNAL	920	1350			
WEIGHT (kg)	0.13				
Dimensional Tolerance	+/-1.5% from nominal dimensions				

TECHNICAL FEATURES	
EAN	8024482189475
Material	Polyester Fabric.



TOP ELECTRA R

Everything within reach

Top Electra R is a **belt-mounted tool pouch** designed to provide speed, lightness and organization during field operations.

TOP ELECTRA R					
DIMENSIONS (mm)	A	B	C	D	E
EXTERNAL	280	70	300		
WEIGHT (kg)	0.25				
Dimensional Tolerance	+/-1.5% from nominal dimensions				

TECHNICAL FEATURES	
EAN	8024482188799
Hookup	Adaptable to the TOP BELT R thanks to a practical loop.
Material	Polyester Fabric.



TOP TOOL BELT R/TOP DRILL R wearables

TOP TOOL BELT R

Instant access to your tools

Top Tool Belt R is designed for professionals who need to keep everything within easy reach, while maintaining agility and comfort throughout their workday.

TOP TOOL BELT R					
DIMENSIONS (mm)	A	B	C	D	E
EXTERNAL	500	230			
WEIGHT (kg)	0.30				
Dimensional Tolerance	+/-1.5% from nominal dimensions				

TECHNICAL FEATURES	
EAN	8024482188782
Material	Polyester Fabric.



TOP DRILL R

Always practical, always quick

Top Drill R is a **belt-mounted drill/driver holster** designed to provide professionals with maximum freedom of movement and instant access to their main tool during operations.

TOP DRILL R					
DIMENSIONS (mm)	A	B	C	D	E
EXTERNAL	150	35	350		
WEIGHT (kg)	0.10				
Dimensional Tolerance	+/-1.5% from nominal dimensions				

TECHNICAL FEATURES	
EAN	8024482189468
Hookup	Adaptable to the TOP BELT R thanks to a practical loop.
Material	Polyester Fabric.





TOP NAIL R/TOP TAPE PLUS R
wearables

TOP NAIL R

Compact, functional and spacious

Top Nail R is a **compact and lightweight nail and small parts pouch**, designed to be attached to a work belt, such as the Top Belt R, ensuring maximum freedom of movement and quick access to materials during daily operations.

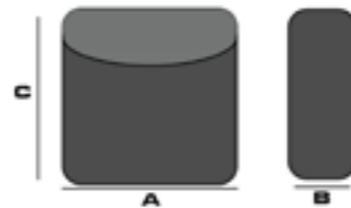

TOP NAIL R					
DIMENSIONS (mm)	A	B	C	D	E
EXTERNAL	160	60	160		
WEIGHT (kg)	0.10				
Dimensional Tolerance	+/-1.5% from nominal dimensions				

TECHNICAL FEATURES	
EAN	8024482189451
Material	Polyester Fabric.

TOP TAPE PLUS R

Maximum practicality and accessibility

Top Tape Plus R is a **compact, lightweight tape measure pouch**, designed to keep essential tools always within easy reach.

TOP TAPE PLUS R					
DIMENSIONS (mm)	A	B	C	D	E
EXTERNAL	120	50	210		
WEIGHT (kg)	0.15				
Dimensional Tolerance	+/-1.5% from nominal dimensions				

TECHNICAL FEATURES	
EAN	8024482189444
Hookup	Adaptable to the TOP BELT R work belt thanks to a practical loop.
Material	Polyester Fabric.



TOP BUMBAG R
wearables

TOP BUMBAG R

Total freedom of movement

The **Top Bumbag R** is a lightweight and practical tool pouch with a padded internal compartment for tool protection.



TOP BUMBAG R					
DIMENSIONS (mm)	A	B	C	D	E
EXTERNAL	320	140	180		
WEIGHT (kg)	0.60				
Dimensional Tolerance	+/-1.5% from nominal dimensions				

TECHNICAL FEATURES	
EAN	8024482189239
Pockets	Internal area with padded pockets for tools.
Material	Polyester Fabric.





TOOL ROLL rolls



TOOL ROLL.12T R

TOOL ROLL.12T R					
DIMENSIONS (mm)	A	B	C	D	E
EXTERNAL	500	320			
WEIGHT (kg)	0.35				
Dimensional Tolerance	+/-1.5% from nominal dimensions				

TECHNICAL FEATURES	
EAN	8024482189437
Pockets	Tool roll with 12 pockets.
Material	Polyester Fabric.

TOOL ROLL

Maximum organization and practicality in every work environment.

Tool Roll R are **compact, lightweight and multifunctional**, designed for professionals who value organization, quick access and maximum efficiency during every task.



TOP TOOL ROLL R

TOP TOOL ROLL R					
DIMENSIONS (mm)	A	B	C	D	E
EXTERNAL	605	540			
WEIGHT (kg)	0.40				
Dimensional Tolerance	+/-1.5% from nominal dimensions				

TECHNICAL FEATURES	
EAN	8024482189406
Handles	Central handle for easy transport.
Panels	Pockets and elastic loops in various sizes.
Locks	Velcro closure.
Material	Polyester Fabric.



TOOL ROLL.15T R

TOOL ROLL.15T R					
DIMENSIONS (mm)	A	B	C	D	E
EXTERNAL	680	320			
WEIGHT (kg)	0.40				
Dimensional Tolerance	+/-1.5% from nominal dimensions				





















TECHNICAL FEATURES	
EAN	8024482189420
Pockets	Tool roll with 15 pockets.
Material	Polyester Fabric.









TOOL ROLL.20T R

TOOL ROLL.20T R					
DIMENSIONS (mm)	A	B	C	D	E
EXTERNAL	790	320			
WEIGHT (kg)	0.50				
Dimensional Tolerance	+/-1.5% from nominal dimensions				

TECHNICAL FEATURES	
EAN	8024482189413
Pockets	Tool roll with 20 pockets.
Material	Polyester Fabric.

 TECHNICAL TABLE		EXTERNAL DIMENSIONS (mm)			WEIGHT	MATERIAL	BACKPACKS	TROLLEY	BAGS tool/PC	BAGS tool
		Lenght	Width	Height	KG					
MONOLITH CROSS LT40		370	300	560	6.22	PL		■		
MONOLITH LT20		370	240	480	2.34	PL	■			
MONOLITH LT35		430	270	570	3.80	PL	■			
TOP 07 R		300	140	400	2.30	PL	■		■	
TOP 10 R		400	130	310	1.40					
BAG 07 R		310	120	390	0.80	PL	■			
TOOL TROLLEY 01 R		360	200	480	4.25	PL		■		
SOFT TROLLEY 01 R		310	190	480	2.50	PL		■		
SOFT PILOT R		420	205	360	2.10	PL			■	
BAG & CASE PTS R		455	170	360	4.00	PL				■
PSS COMPACT BAG R		330	110	330	1.50	PL				■
TOP 04 R		410	230	300	1.30					
TOP 06 R		515	210	300	1.55					
TOP 08 L R		420	60	300	1.30	PL				■
BAG 04 R		320	210	240	0.50	PL				■
BAG 05 R		400	55	310	0.70					
BAG 06 R		510	200	270	1.20					
TOP BELT R		920	1350		0.13	PL				
TOP ELECTRA R		280	70	300	0.25	PL				
TOP TOOL BELT R		500	230		0.30	PL				
TOP DRILL R		150	35	350	0.10	PL				
TOP NAIL R		160	60	160	0.10	PL				
TOP TAPE PLUS R		120	50	210	0.15	PL				
TOP BUMBAG R		320	140	180	0.60	PL				
TOOL ROLL R		605	540		0.40	PL				
TOOL ROLL.12T R		500	320		0.35					
TOOL ROLL.15T R		680	320		0.40					
TOOL ROLL.20T R		790	320		0.50					

BASKETS tool	WEARABLES	ROLL								P. N°
			■	■	■	■	■	■		86
			■	■	■		■	■		88
			■	■	■		■	■		90
			■	■	■		■	■		92
			■	■	■			■		94
			■	■	■	■	■	■		95
			■	■	■	■	■	■		97
			■	■	■		■	■	■	99
			■	■	■			■		101
			■		■					102
			■	■	■			■		103
			■	■	■			■		105
	■									108
	■		■		■					108
	■		■		■					109
	■		■							109
	■		■							110
	■		■		■					110
	■		■		■					111
		■	■							112

ACCESSORIES

ALL IN ONE MODULAR SYSTEM

	BOXES WL							
		WLO1 Dim (mm): 163x120x30 WEIGHT: 0.08 kg	WLO2 Dim (mm): 163x120x30 WEIGHT: 0.08 kg	WLO3 Dim (mm): 163x120x30 WEIGHT: 0.08 kg	WLO4 Dim (mm): 245x130x30 WEIGHT: 0.25 kg	WLO5 Dim (mm): 245x130x30 WEIGHT: 0.25 kg		
			ATOMIK ATOMIKNEO ATOMIKNEOWH					
				FOAM ATOMIK Pre-cubed foam layers to customize the interior of the case.	LOCK ATOMIK Set of combination locks	PAN ATOMIK Additional panel with PSS™ system and elastic loops on one side, and elastic loops only on the other.	KEYLOCKATOMIK Only for Atomik WH Neo L	
					AI1 GT 44-19 GT 48-25HL GT 52-21 GT 53 - 26 MUB			
EXPL COMBILOCK Patented combination padlock	EXPL PADLOCK Patented key padlock					TSA DIGILOCK TSA™ approved combination padlock		
	MUB	FOAM MUB78 Pre-cubed foam in the bottom and convoluted foam in the lid				KIT TRAY MUB		
			GT 44 - 19		SHOULDER KIT Shoulder strap			
	GT 52 - 21			BACKPACK CABIN				

	AI1	AIDRAW			
			AIDRAW3.E Empty 467x255xh30 mm	AIDRAW6.E Empty 467x255xh60 mm	AIDRAW9.E Empty 467x255xh95 mm
			AIDRAW3.F With Foam 467x255xh30 mm	AIDRAW6.F With Foam 467x255xh60 mm	AIDRAW9.F With Foam 467x255xh95 mm
				AIDRAW6.B1 Bin Boxes 467x255xh60 mm	AIDRAW9.B1 Bin Boxes 467x255xh95 mm
	AI1X AI1MOD31X	AIBOX			
			AIBOX3.E With Foam 467x255xh30 mm	AIBOX6.E With Foam 467x255xh60 mm	AIBOX9.E With Foam 467x255xh95 mm
			AIBOX3.F With Foam 467x255xh30 mm	AIBOX6.F With Foam 467x255xh60 mm	AIBOX9.F With Foam 467x255xh95 mm
				AIBOX6.B1 Bin Boxes 467x255xh60 mm	AIBOX9.B1 Bin Boxes 467x255xh95 mm
AI1 AI1X AI1MOD	AIPANEL				
		AIPANEL PSS.A	AIPANEL PLEXI	AIPANEL PEL No AIMOD31	
	AIPANEL PSS.B	AIPANEL PSS.M	AIPANEL PTS No AIMOD31		
	AIPANEL PFR				
AI1 AI1X	AI WHEELS		AI WHEELS		
			AIPANEL IPAD		



1908	1913	2209	2214	2437	2712
INTERNAL DIMENSIONS	INTERNAL DIMENSIONS	INTERNAL DIMENSIONS	INTERNAL DIMENSIONS	INTERNAL DIMENSIONS	INTERNAL DIMENSIONS
190x125x85 mm	190x125x135 mm	220x160x95 mm	220x160x145 mm	249x240x370 mm	276x200x120 mm
7 1/2 x 4 15/16 x 3 3/8 in	7 1/2 x 4 15/16 x 5 5/16 in	8 11/16 x 6 5/16 x 3 3/4 in	8 11/16 x 6 5/16 x 5 11/16 in	9 51/64 x 9 29/64 x 14 9/16 in	10 7/8 x 7 7/8 x 4 3/4 in
VOLUME L: 2	VOLUME L: 3.2	VOLUME L: 3.3	VOLUME L: 5.19	VOLUME L: 21.3	VOLUME L: 6.6
WEIGHT KG: empty 0.7 full 0.8	WEIGHT KG: empty 0.85 full 0.92	WEIGHT KG: empty 0.88 full 0.99	WEIGHT KG: empty 1.16 full 1.29	WEIGHT KG: empty 2.45 full 2.87	WEIGHT KG: empty 1.62 full 1.83
BUOYANCY KG MAX: 1.4	BUOYANCY KG MAX: 2.4	BUOYANCY KG MAX: 2.3	BUOYANCY KG MAX: 3.9	BUOYANCY KG MAX: 15.6	BUOYANCY KG MAX: 4.2

2712HL	2717	2717HL	3005	3110HL	3317
INTERNAL DIMENSIONS	INTERNAL DIMENSIONS	INTERNAL DIMENSIONS	INTERNAL DIMENSIONS	INTERNAL DIMENSIONS	INTERNAL DIMENSIONS
276x200x120 mm	276x200x170 mm	276x200x170 mm	300x210x58 mm	330x234x170 mm	330x234x170 mm
10 7/8 x 7 7/8 x 4 3/4 in	10 7/8 x 7 7/8 x 6 11/16 in	10 7/8 x 7 7/8 x 6 11/16 in	11 13/16 x 8 1/4 x 2 5/16 in	13 x 9 3/16 x 6 11/16 in	13 x 9 3/16 x 6 11/16 in
VOLUME L: 6.6	VOLUME L: 9.3	VOLUME L: 9.4	VOLUME L: 4	VOLUME L: 3.4	VOLUME L: 13.1
WEIGHT KG: empty 1.32 full 1.46	WEIGHT KG: empty 1.93 full 2.12	WEIGHT KG: empty 1.54 full 1.75	WEIGHT KG: empty 1.1 full 1.2	WEIGHT KG: empty 0.95 full 1.05	WEIGHT KG: empty 2.29 full 2.51
BUOYANCY KG MAX: 4.2	BUOYANCY KG MAX: 6.7	BUOYANCY KG MAX: 6.7	BUOYANCY KG MAX: 2.1	BUOYANCY KG MAX: 2.5	BUOYANCY KG MAX: 7.0

3317HL	3317W	3815HL	3818	3818HL	3823HL
INTERNAL DIMENSIONS	INTERNAL DIMENSIONS	INTERNAL DIMENSIONS	INTERNAL DIMENSIONS	INTERNAL DIMENSIONS	INTERNAL DIMENSIONS
330x234x170 mm	330x350x170 mm	380x270x155 mm	380x270x180 mm	380x270x180 mm	380x270x230 mm
13 x 9 3/16 x 6 11/16 in	13 x 13 3/4 x 6 11/16 in	14 15/16 x 10 5/8 x 6 1/8 in	14 15/16 x 10 5/8 x 7 1/16 in	14 15/16 x 10 5/8 x 7 1/16 in	14 15/16 x 10 5/8 x 9 1/16 in
VOLUME L: 13.1	VOLUME L: 19.6	VOLUME L: 15.9	VOLUME L: 18.4	VOLUME L: 18.5	VOLUME L: 23.6
WEIGHT KG: empty 1.78 full 2.02	WEIGHT KG: empty 2.93 full 3.3	WEIGHT KG: empty 2.2 full 2.53	WEIGHT KG: empty 3.14 full 3.58	WEIGHT KG: empty 2.26 full 2.66	WEIGHT KG: empty 2.59 full 3.09
BUOYANCY KG MAX: 7.1	BUOYANCY KG MAX: 10.6	BUOYANCY KG MAX: 10	BUOYANCY KG MAX: 12.4	BUOYANCY KG MAX: 12.3	BUOYANCY KG MAX: 16

4209HL	4216HL	4412	4412HL	4419	4419HL
INTERNAL DIMENSIONS	INTERNAL DIMENSIONS	INTERNAL DIMENSIONS	INTERNAL DIMENSIONS	INTERNAL DIMENSIONS	INTERNAL DIMENSIONS
420x300x95 mm	420x300x160 mm	445x345x125 mm	445x345x125 mm	445x345x190 mm	445x345x190 mm
16 9/16 x 11 13/16 x 3 3/4 in	16 9/16 x 11 13/16 x 6 5/16 in	17 1/2 x 13 9/16 x 4 15/16 in	17 1/2 x 13 9/16 x 4 15/16 in	17 1/2 x 13 9/16 x 7 1/2 in	17 1/2 x 13 9/16 x 7 1/2 in
VOLUME L: 12	VOLUME L: 20.6	VOLUME L: 19.2	VOLUME L: 19.2	VOLUME L: 29.2	VOLUME L: 29.2
WEIGHT KG: empty 2.2 full 2.6 bag 2.8	WEIGHT KG: empty 2.6 full 3.2	WEIGHT KG: empty 3.4 full 3.9	WEIGHT KG: empty 2.5 full 2.92 bag 3.22	WEIGHT KG: empty 4 full 4.7	WEIGHT KG: empty 2.91 full 3.58
BUOYANCY KG MAX: 6.8	BUOYANCY KG MAX: 14.2	BUOYANCY KG MAX: 10.7	BUOYANCY KG MAX: 10.8	BUOYANCY KG MAX: 19.7	BUOYANCY KG MAX: 19.8

4820	4820HL	4825HL	5116	5117	5122
INTERNAL DIMENSIONS	INTERNAL DIMENSIONS	INTERNAL DIMENSIONS	INTERNAL DIMENSIONS	INTERNAL DIMENSIONS	INTERNAL DIMENSIONS
480x370x205 mm	480x370x205 mm	480x370x255 mm	516x296x160 mm	517x277x173 mm	517x277x217 mm
18 7/8 x 14 9/16 x 8 1/16 in	18 7/8 x 14 9/16 x 8 1/16 in	18 7/8 x 14 9/16 x 10 1/16 in	20 5/16 x 11 5/8 x 6 5/16 in	20 3/8 x 10 7/8 x 6 13/16 in	20 3/8 x 10 7/8 x 8 9/16 in
VOLUME L: 35.5	VOLUME L: 36.4	VOLUME L: 39	VOLUME L: 24.4	VOLUME L: 24.7	VOLUME L: 31
WEIGHT KG: empty 4.64 full 5.4	WEIGHT KG: empty 3.41 full 4.17	WEIGHT KG: empty 4.5 full 5.3	WEIGHT KG: empty 3.5 full 4	WEIGHT KG: empty 3.8 full 4.5	WEIGHT KG: empty 6 full 7
BUOYANCY KG MAX: 24.7	BUOYANCY KG MAX: 24.8	BUOYANCY KG MAX: 28.2	BUOYANCY KG MAX: 15.1	BUOYANCY KG MAX: 15.8	BUOYANCY KG MAX: 21.5

5131	5140	5212HL	5215HL	5218HL	5221HL
INTERNAL DIMENSIONS	INTERNAL DIMENSIONS	INTERNAL DIMENSIONS	INTERNAL DIMENSIONS	INTERNAL DIMENSIONS	INTERNAL DIMENSIONS
516x296x310 mm	581x381x455 mm	520x285x125 mm	520x285x150 mm	520x285x180 mm	520x285x205 mm
20 5/16 x 11 5/8 x 12 3/16 in	22 7/8 x 15 x 17 15/16 in	20 1/2 x 11 1/4 x 4 15/16 in	20 1/2 x 11 1/4 x 5 7/8 in	20 1/2 x 11 1/4 x 7 1/16 in	20 1/2 x 11 1/4 x 8 1/16 in
VOLUME L: 47.3	VOLUME L: 31	VOLUME L: 18.5	VOLUME L: 22.2	VOLUME L: 26	VOLUME L: 30.3
WEIGHT KG: empty 5 full 5.5	WEIGHT KG: BKT01.AH 13 BKT02.AH BKT03.AH 13.8 BKTE.AH X.B 9.75 BE.AH 7.52	WEIGHT KG: empty 2.35 full 2.85	WEIGHT KG: empty 2.55 full 3.05	WEIGHT KG: empty 3.75 full 4.3	WEIGHT KG: empty 3.9 full 4.5
BUOYANCY KG MAX: 34.4		BUOYANCY KG MAX: 12.7	BUOYANCY KG MAX: 12.7	BUOYANCY KG MAX: 20	BUOYANCY KG MAX: 20



HL SERIES

The new standard for lightweight cases, with no compromise on durability or reliability.

Featuring enhanced strength and over 30% less weight.

5325	5326	5822	5823	5833	7626HL
INTERNAL DIMENSIONS	INTERNAL DIMENSIONS	INTERNAL DIMENSIONS	INTERNAL DIMENSIONS	INTERNAL DIMENSIONS	INTERNAL DIMENSIONS
538x405x250 mm	538x405x250 mm	580x440x220 mm	580x440x220 mm	580x440x330 mm	763x399x260 mm
21 3/16 x 15 15/16 x 9 13/16 in	21 3/16 x 15 15/16 x 9 13/16 in	22 13/16 x 17 5/16 x 8 11/16 in	22 13/16 x 17 5/16 x 8 11/16 in	22 13/16 x 17 5/16 x 13 in	30 1/16 x 15 11/16 x 10 1/4 in
VOLUME L: 53	VOLUME L: 53	VOLUME L: 56.1	VOLUME L: 56.1	VOLUME L: 84.2	VOLUME L: 79.2
WEIGHT KG: empty 7 full 8.25	WEIGHT KG: empty 10 full 11.25	WEIGHT KG: empty 7.16 full 8.39	WEIGHT KG: empty 9.17 full 10.4	WEIGHT KG: empty 10.54 full 12.65	WEIGHT KG: empty 7.7 full 9.5
BUOYANCY KG MAX: 37.2	BUOYANCY KG MAX: 37.2	BUOYANCY KG MAX: 36.7	BUOYANCY KG MAX: 36.7	BUOYANCY KG MAX: 62	BUOYANCY KG MAX: 57.5

INTELLIRESPOND System

Smart Case System with integrated RFID NFC technology

7630	7635HL	7641	7726	7745	7814HL
INTERNAL DIMENSIONS	INTERNAL DIMENSIONS	INTERNAL DIMENSIONS	INTERNAL DIMENSIONS	INTERNAL DIMENSIONS	INTERNAL DIMENSIONS
765x485x305 mm	763x399x350 mm	765x485x415 mm	770x580x265 mm	770x580x450 mm	780x350x145 mm
30 1/8 x 19 1/8 x 12 in	30 1/16 x 15 11/16 x 13 3/4 in	30 1/8 x 19 1/8 x 16 5/16 in	30 5/16 x 22 13/16 x 10 7/16 in	30 5/16 x 22 13/16 x 17 11/16 in	30 11/16 x 13 3/4 x 5 11/16 in
VOLUME L: 113.1	VOLUME L: 106.6	VOLUME L: 153.9	VOLUME L: 118	VOLUME L: 200	VOLUME L: 39.6
WEIGHT KG: empty 13.56 full 16.39	WEIGHT KG: empty 9.4 full 11.8	WEIGHT KG: empty 15.02 full 18.87	WEIGHT KG: empty 10.3 full 12.6	WEIGHT KG: empty 15.5 full 19.8	WEIGHT KG: empty 5.5 full 6.4
BUOYANCY KG MAX 81.8	BUOYANCY KG MAX 82.2	BUOYANCY KG MAX 118.5	BUOYANCY KG MAX 70	BUOYANCY KG MAX 144	BUOYANCY KG MAX 25.3
8830HL	8831HL	9413	9433	10826	10840
INTERNAL DIMENSIONS	INTERNAL DIMENSIONS	INTERNAL DIMENSIONS	INTERNAL DIMENSIONS	INTERNAL DIMENSIONS	INTERNAL DIMENSIONS
880x300x305 mm	880x300x305 mm	936x350x135 mm	936x350x330 mm	1080x620x260 mm	1080x620x400 mm
34 41/64 x 11 13/16 x 12 1/64 in	34 41/64 x 11 13/16 x 12 1/64 in	36 7/8 x 13 3/4 x 5 5/16 in	36 7/8 x 13 3/4 x 13 in	42 1/2 x 24 7/16 x 10 1/4 in	42 1/2 x 24 7/16 x 15 3/4 in
VOLUME L: 80.5	VOLUME L: 80.5	VOLUME L: 45.3	VOLUME L: 108	VOLUME L: 174	VOLUME L: 260
WEIGHT KG: empty 6.9 full 8.8	WEIGHT KG: empty 7.8 full 9.7	WEIGHT KG: empty 6.7 full 7.7	WEIGHT KG: empty 10.2 full 12.7	WEIGHT KG: empty 17 full 20.4	WEIGHT KG: empty 19.8 full 26.3
BUOYANCY KG MAX 61.8	BUOYANCY KG MAX 61.8	BUOYANCY KG MAX 27.9	BUOYANCY KG MAX 84.9	BUOYANCY KG MAX 120.6	BUOYANCY KG MAX 120.6
11413	13513	13527	15416		
INTERNAL DIMENSIONS	INTERNAL DIMENSIONS	INTERNAL DIMENSIONS	INTERNAL DIMENSIONS		
1136x350x135 mm	1350x350x135 mm	1350x350x272 mm	1540x377x160 mm		
44 3/4 x 13 3/4 x 5 5/16 in	53 1/8 x 13 3/4 x 5 5/16 in	53 1/8 x 13 3/4 x 10 11/16 in	60 5/8 x 14 13/16 x 6 5/16 in		
VOLUME L: 53.7	VOLUME L: 63.7	VOLUME L: 128.5	VOLUME L: 92.9		
WEIGHT KG: empty 7.8 full 8.8	WEIGHT KG: empty 8.7 full 9.95	WEIGHT KG: empty 11.7 full 14.9	WEIGHT KG: empty 11.3 full 13.4		
BUOYANCY KG MAX 33.3	BUOYANCY KG MAX 39.5	BUOYANCY KG MAX 97.5	BUOYANCY KG MAX 61.6		



**WATERTIGHT SEAL
IP67 HERMETIC**

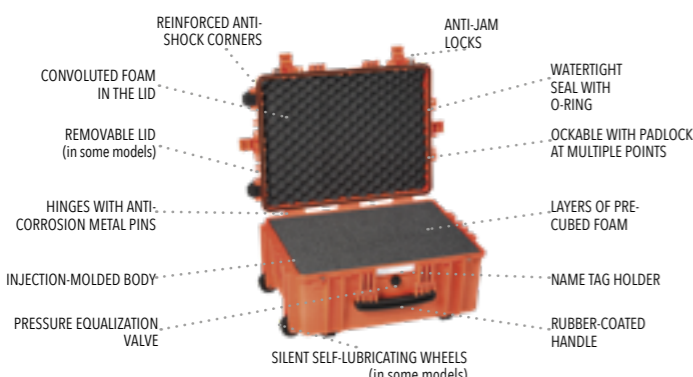

COLORS



Not all colors are available for every model. Please refer to the technical table above.

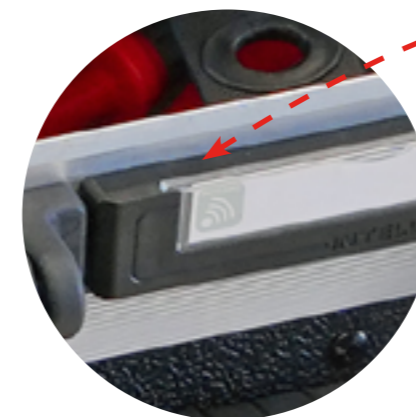

www.intellirespond.com



**Power up your case
by connecting it
to the web!**

IntelliRespond is the smartest and most innovative way to manage your cases. At the heart of the system is the "IntelliRespond App." Available for iOS and Android devices, this app manages a wide range of useful functions:

- MY PRODUCT**
Access to all information related to your case (model, technical specifications, user manuals, warranty, and more).
- KIT MANAGER**
Content management: allows you to register, track, and view the contents of your case without opening it.
- MY SERVICE**
Online customer service for any type of request (replacements, spare parts, technical support, and more).
- NOTIFICATIONS**
Receive free product updates and useful information to support your professional activity.

**THIS PRODUCT CAN
BE USED WITH OUR
APP INTELLIRESPOND**



* Warranty valid only if the product has been used appropriately. Explorer Cases is responsible solely for the case itself and not for any damage to its contents. For further details, please contact us.

MP.0494
DOUBLE-SIDED
MDF DISPLAY –
SIDE A
dim. 53 x 36 x 163 cm



MP.0494
DOUBLE-SIDED
MDF DISPLAY –
SIDE B
dim. 53 x 36 x 163 cm

MP.0547
CARDBOARD DISPLAY
dim. 61 x 61 x 154 cm



**L-Banner
MP.0558**
dim. 80 x 200 cm



**L-Banner
MP.0561**
dim. 80 x 200 cm



**L-Banner
MP.0557**
dim. 80 x 200 cm



**L-Banner
MP.0529**
dim. 90 x 200 cm



MP.0257



MP.0456
OVERVIEW TABLE
dim 60 x 40 cm



**L-Banner
MP.0552**
dim. 80 x 200 cm



GT Line srl a socio unico

Via del Lavoro, 9 - Loc. Crespellano
40053 Valsamoggia (BO) - Italy
Tel. +39 051 65041
sales@gtline.com
www.gtline.com

follow us    



REG. N. 1594-A
UNI EN ISO 9001:2015

The data contained in this catalog are provided for informational purposes only. GT reserves the right to make changes to the models described at any time for technical or commercial reasons. It is recommended to always check for updates on the website www.gtline.com. The tool cases are supplied without tools. All trademarks and logos are the property of their respective owners.